



## *DuraLED*<sup>®</sup> Universal High Efficacy White Lamp Multivolt 9 - 33 volts

### Introduction

HELLA LED lamps offer many advantages over conventional bulb lamps including significantly reduced power consumption, and a high tolerance to shock and vibration for an ultra long service life.

#### Features Include:

- *DuraLED*<sup>®</sup> = Fully sealed against water and dust
- *DuraLED*<sup>®</sup> = Vibration and shock resistant
- *DuraLED*<sup>®</sup> = Ultra long service life
- *DuraLED*<sup>®</sup> = Enhanced circuit protection
- *DuraLED*<sup>®</sup> = Reverse polarity protected
- *DuraLED*<sup>®</sup> = Low power consumption
- *DuraLED*<sup>®</sup> = Lens is manufactured from Grilamid<sup>®</sup> which is characterised by very high impact and fatigue strength with resistance to chemicals and stress cracking.

### Installation

#### Screw Cap Removal

Carefully insert a small flat blade screwdriver between the cap and the lens and pull towards the lens, the cap will clip off.

To install the cap push in by hand until the top is flush with the lens.

#### Surface Mounting

- Drill two holes up to 6.5mm Ø at 193mm centres.
- 6mm Ø screws or bolts are recommended to mount the lamp using the mounting bushes provided.
- Lamp should be mounted on a flat surface.
- If passing the cable through a hole, ensure there are no sharp edges to cut or chafe the cable.
- Alternatively, cable can be routed through the end of the base.
- Connect cable as per chart below.
- Clip the screw caps on securely until flush with the lamp surface

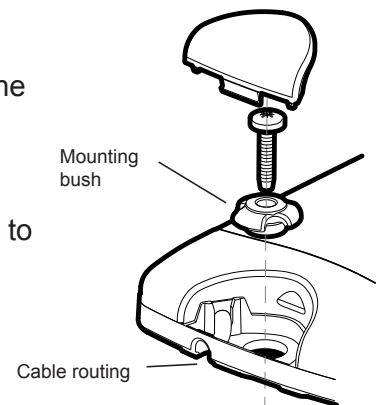

Note: Bolts not included

*Note: When mounting lamp units side by side allow a gap of 5mm to ensure screw cap removal.*

### Wiring Colour Coding

LED modules are polarity conscious. Reverse polarity will not damage this product but will inhibit its function.

HELLA recommends wire connections be soldered, and heat shrink tubing applied to seal the joint.

Colour	Connect to	Power Consumption
White	Negative (-)	-
Yellow	Signal (+)	Less than 12 watts

**NB:** Lamp must be protected by a fuse rated at 5 amperes maximum.

## INSTRUCTION SHEET

for: **Part No. 2JA 980 604-5xx / 9806045x**



### Introduction

This Multivolt LED lamp offers many advantages over conventional bulb lamps. Significantly reduced power consumption, ultra long life and high tolerance to shock and vibration make this LED lamp the ideal choice for industrial and commercial applications.

### Electromagnetic Compatibility (EMC)

This Multivolt LED lamp is an electronic device. The electrical circuits contain components that suppress possible interference, both emission as well as susceptibility, to the technical requirements for the application of the Regulatory Compliance Mark (RCM) and CE Mark.

To avoid false signals or interference, it is standard practice that sensitive instrumentation such as ABS and Tachometers etc. are provided with direct earths.

### Protection against damage due to voltage spikes

This LED lamp is protected against damage from positive voltage spikes caused by events such as load dump conditions up to severity level 3 of ISO 7637-2. The lamp is protected against reverse polarity connection and negative voltage spikes of up to 1000 volts.

### Electric Welding

Electric Welding may damage the LED lamps. For LED lamps, HELLA recommends the negative connection to be wired isolated from the vehicle chassis. If the lamp uses the chassis as the earth return it is recommended that this earth return is disconnected during electric welding.

### General Dimensions (mm)

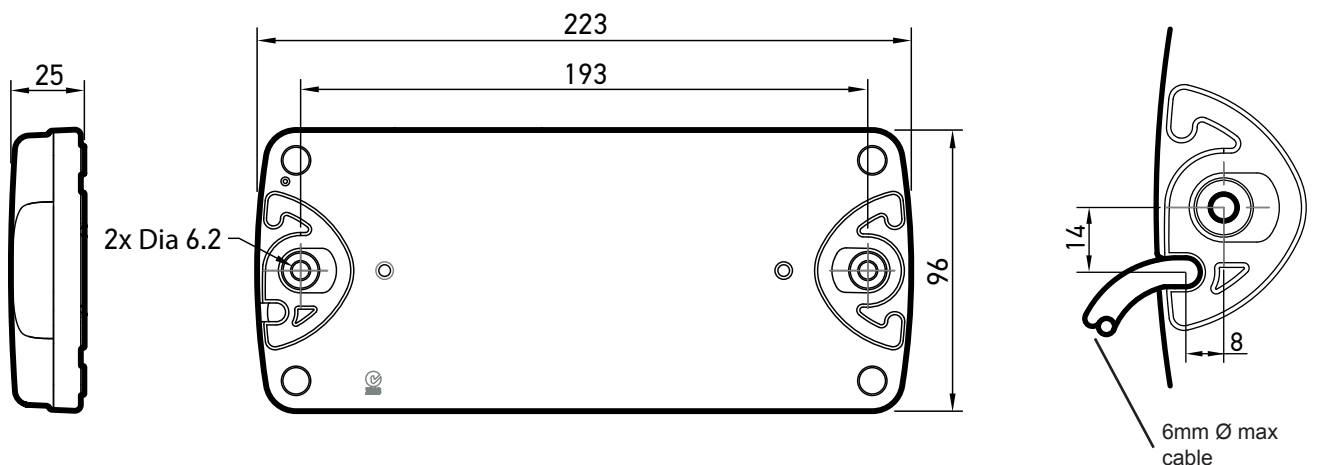

## ***FIT AND FORGET - BY DESIGN***

Congratulations, the product you have selected comes from **HELLA** - a world leader in LED lighting design.

Following the launch of the first LED automotive signal lamps in 1990, **HELLA** Design and Innovation continues to set new standards. **HELLA** innovative solutions have been incorporated into millions of lamps, engineered and tested to the most stringent standards, to suit the most demanding environmental conditions.

The cornerstone to the success of our products is our no compromise **Fit and Forget - by Design** philosophy which is incorporated into every step of the product life cycle.

In a world consuming finite resources at an ever faster rate, **Fit and Forget - by Design** is the right environmental choice that also makes perfect economic sense to customers that consider the total life cycle Cost of Ownership.

For general comments about Hella's products please contact us on E-mail at [techfeedback@hella.co.nz](mailto:techfeedback@hella.co.nz)

