



ADR - APPLICATION AND MOUNTING INSTRUCTIONS
ADR 74/00 SIDE MARKER LAMP
ADR 45/01 SIDE MARKER LAMP (Pre 18/11/2017 Compliance Date)

DuraLED® FLUSH MOUNT SIDE MARKER LAMP
Multivolt (Suitable for 12 and 24 volt systems)

Lens Marking and ADR 13/00 Installation Requirements

This Side Marker Lamp, identified by lens marking 0868 and the logo was manufactured to comply with ADR 74/00 & 45/01 Side Marker Lamps.

- A tolerance of +/-3° applies on all mounting details.
- Lamp mounting surface must be vertical to the ground and be parallel to the vehicle longitudinal axis.
- Lamp reference axis must be horizontal, with the light from the red LED facing rearward.
- Lamp must be visible between:
 - Horizontal angle: From 5° out to 85° out at the front and at the rear
 - Vertical angle: 10° above and below the horizontal

Note: Please refer to ADR 13/00 for more details.

General Dimensions (in millimetres)

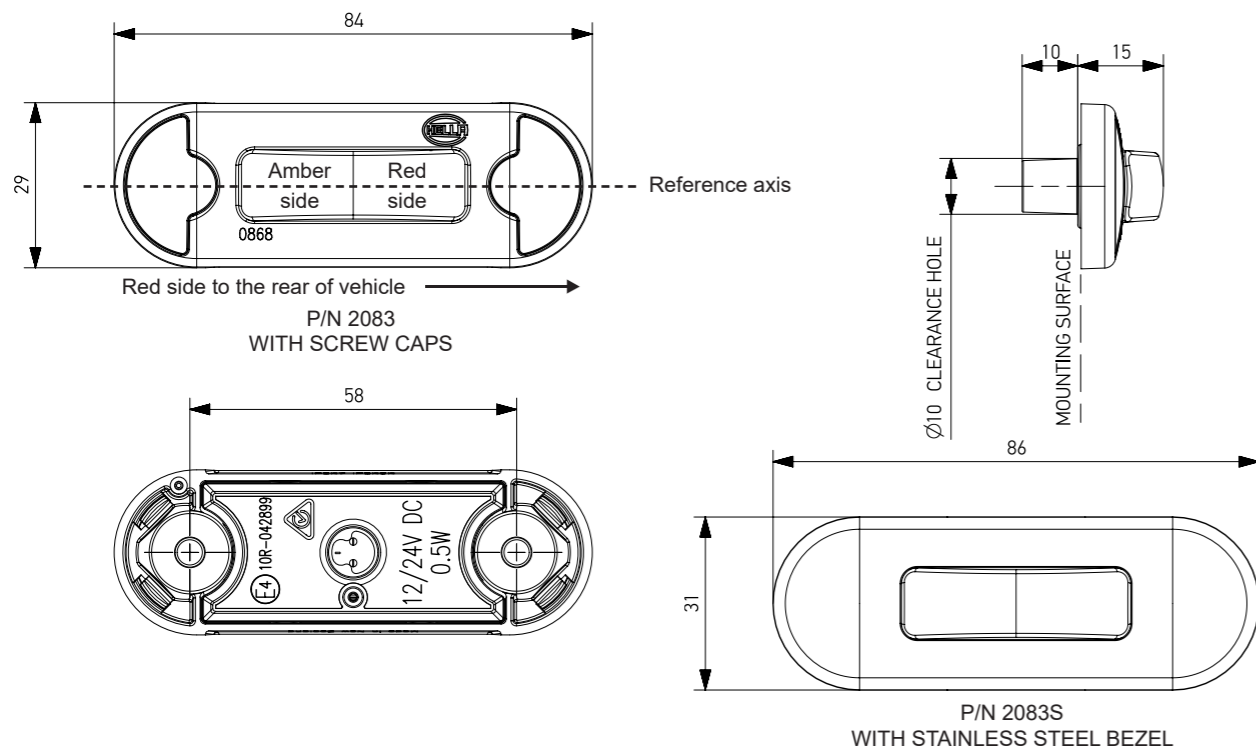

PART NUMBER	CTA NUMBER	ADR 51/00 GLOBE	LENS IDENTIFICATION NO.
2083 (S) 2PS 980 868-xxx 980.868-xxx	CTA-047116	N/A LED	0868

HELLA-New Zealand Limited, Auckland



ADR - APPLICATION AND MOUNTING INSTRUCTIONS
ADR 74/00 SIDE MARKER LAMP
ADR 45/01 SIDE MARKER LAMP (Pre 18/11/2017 Compliance Date)

DuraLED® FLUSH MOUNT SIDE MARKER LAMP
Multivolt (Suitable for 12 and 24 volt systems)

Lens Marking and ADR 13/00 Installation Requirements

This Side Marker Lamp, identified by lens marking 0868 and the logo was manufactured to comply with ADR 74/00 & 45/01 Side Marker Lamps.

- A tolerance of +/-3° applies on all mounting details.
- Lamp mounting surface must be vertical to the ground and be parallel to the vehicle longitudinal axis.
- Lamp reference axis must be horizontal, with the light from the red LED facing rearward.
- Lamp must be visible between:
 - Horizontal angle: From 5° out to 85° out at the front and at the rear
 - Vertical angle: 10° above and below the horizontal

Note: Please refer to ADR 13/00 for more details.

General Dimensions (in millimetres)

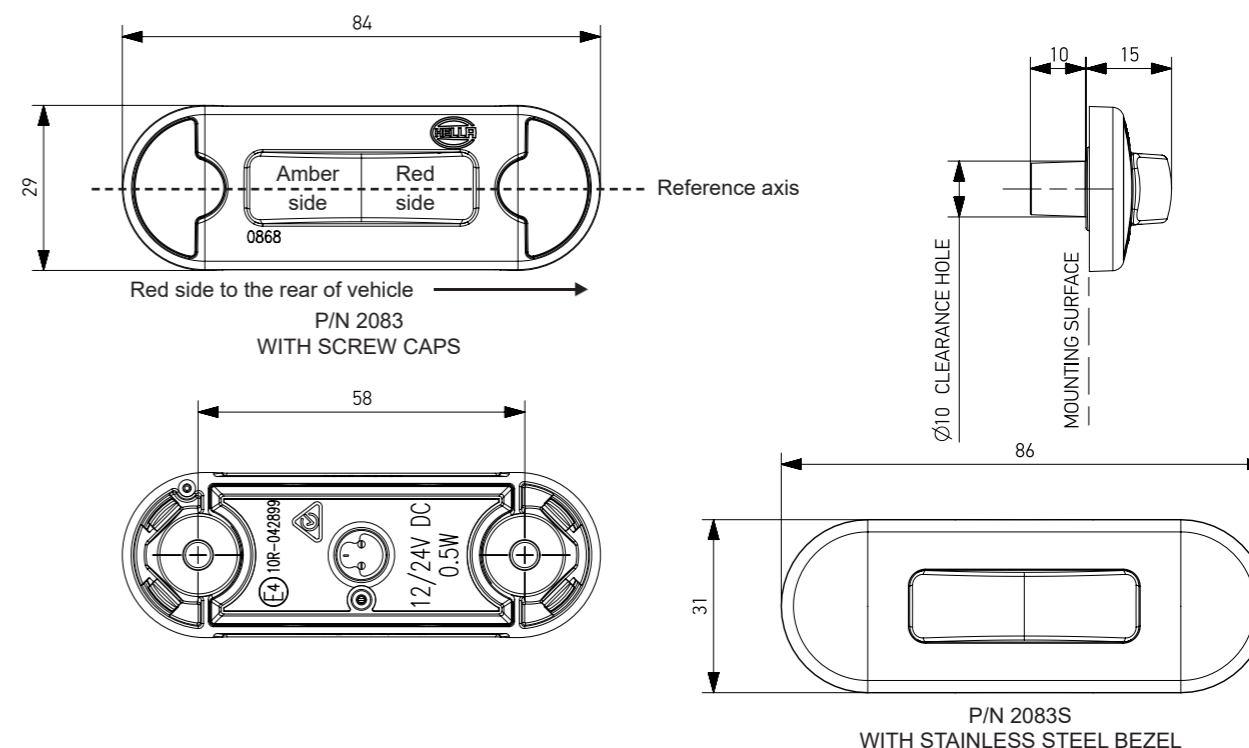

PART NUMBER	CTA NUMBER	ADR 51/00 GLOBE	LENS IDENTIFICATION NO.
2083 (S) 2PS 980 868-xxx 980.868-xxx	CTA-047116	N/A LED	0868

HELLA-New Zealand Limited, Auckland

INSTRUCTION SHEET
for: **2PS 980 868-xxx / 2083(S)**



Lamp Mounting Instructions

- Lamp should be mounted on a flat surface with no curvature.
- Drill a minimum hole size of Ø10 mm through the mounting surface for the centre cable exit. The lamp can then be used as a template to mark the location of the mounting holes.
- Drill two mounting holes up to Ø5.5 mm at 58 mm centres through the mounting surface.
- Fasten the lamp, with a maximum torque of 2.5 Nm, to the mounting surface using two Ø5 mm screws or bolts (not included). For P/N 2083 a maximum screw head height of 4 mm is recommended.
- P/N 2083: Once the lamp is mounted, clip the screw caps on securely until flush with the lens surface.
- P/N 2083S: Once the lamp is mounted, clip the stainless steel bezel on securely to the lens.

Note: Do not use countersunk screws or overtighten the mounting screws in the plastic lens. Lamp is fully sealed and has no serviceable components.

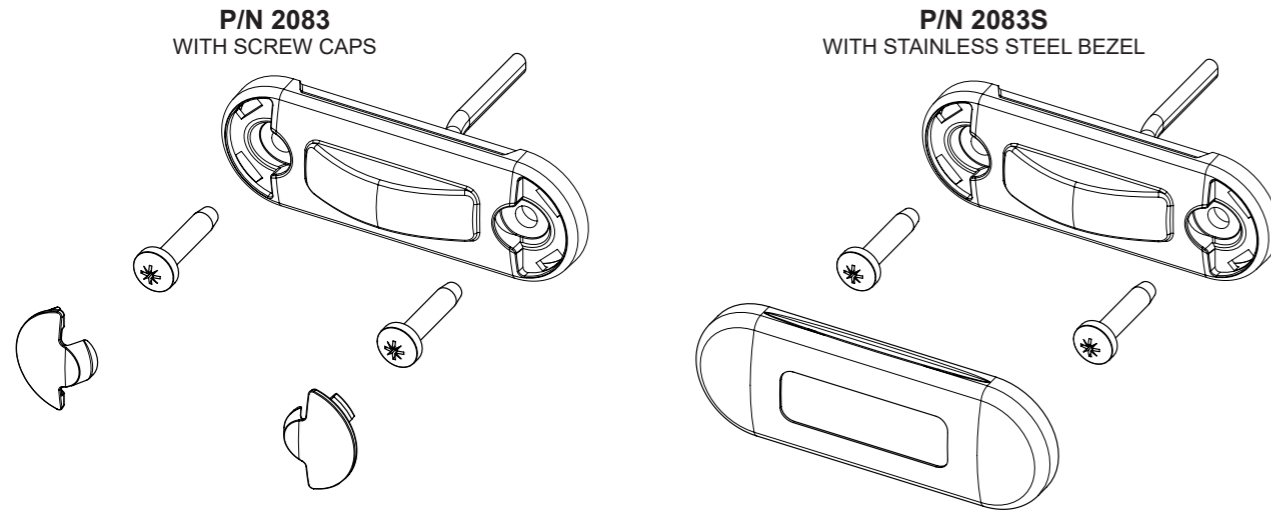

Wiring Colour Coding

The LED lamp is multi voltage capable for optimum brightness in 12 and 24 Volt systems. LED modules are polarity conscious. Reverse polarity will not damage this product but will inhibit its function. HELLA recommends wire connections be soldered, and heat shrink tubing applied to seal the joint.

Colour	Connect to	Power Consumption
Black	Earth (-)	-
Red	Positive (+)	0.5 W

NB: Lamp must be protected by a fuse rated at 2 amperes maximum.

Compatibility to existing electrical systems

It is important for the installer to ascertain the compatibility of the low power consumption LED lamps with the electrical and/or electronic systems of the complete vehicle, including trailers. In most cases the reduced power consumption is beneficial by imposing less demands on the entire electrical system.

For certain functions some electrical systems rely on a set power consumption for monitoring whether, for example, a trailer is connected.

Operation of this lamp using alternating current or modulated direct voltage will cause premature light failure. HELLA recommends connecting ADR or ECE certified Multivolt LED signal and marker lamps to a continuous (unmodulated) 12V or 24V power supply to ensure safe light operation.

FIT AND FORGET - BY DESIGN

Congratulations, the product you have selected comes from **HELLA** - a world leader in LED lighting design.

Following the launch of the first LED automotive signal lamps in 1990, **HELLA** Design and Innovation continues to set new standards. **HELLA** innovative solutions have been incorporated into millions of lamps, engineered and tested to the most stringent standards, to suit the most demanding environmental conditions.

The cornerstone to the success of our products is our no compromise **Fit and Forget - by Design** philosophy which is incorporated into every step of the product life cycle.

In a world consuming finite resources at an ever faster rate, **Fit and Forget - by Design** is the right environmental choice that also makes perfect economic sense to customers that consider the total life cycle Cost of Ownership.

For general comments about HELLA's products please contact us on E-mail at techfeedback@hella.co.nz



INSTRUCTION SHEET
for: **2PS 980 868-xxx / 2083(S)**



Lamp Mounting Instructions

- Lamp should be mounted on a flat surface with no curvature.
- Drill a minimum hole size of Ø10 mm through the mounting surface for the centre cable exit. The lamp can then be used as a template to mark the location of the mounting holes.
- Drill two mounting holes up to Ø5.5 mm at 58 mm centres through the mounting surface.
- Fasten the lamp, with a maximum torque of 2.5 Nm, to the mounting surface using two Ø5 mm screws or bolts (not included). For P/N 2083 a maximum screw head height of 4 mm is recommended.
- P/N 2083: Once the lamp is mounted, clip the screw caps on securely until flush with the lens surface.
- P/N 2083S: Once the lamp is mounted, clip the stainless steel bezel on securely to the lens.

Note: Do not use countersunk screws or overtighten the mounting screws in the plastic lens. Lamp is fully sealed and has no serviceable components.

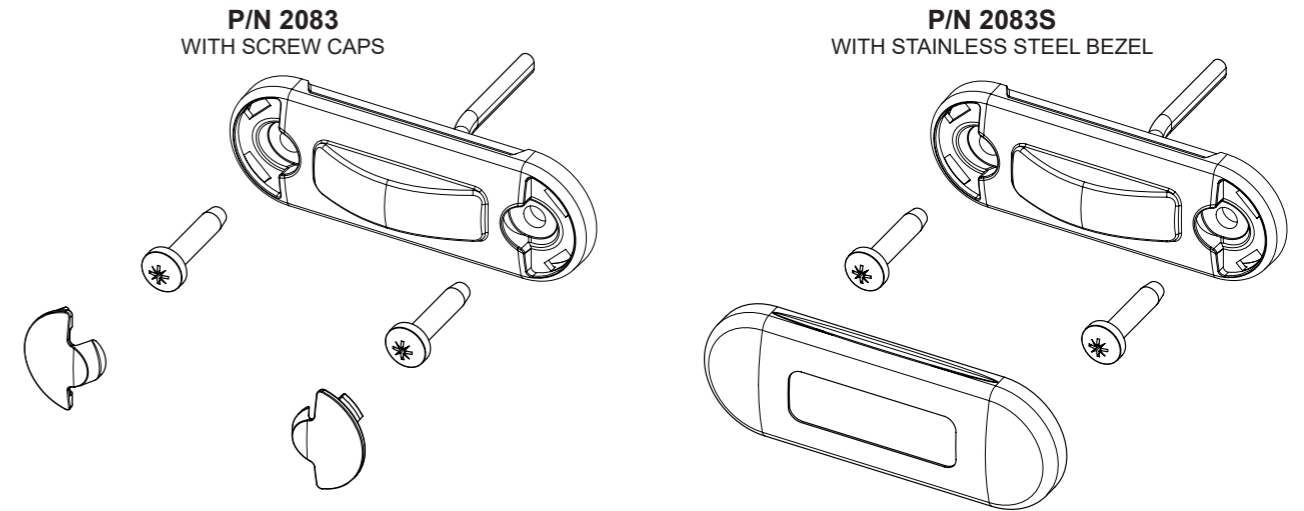

Wiring Colour Coding

The LED lamp is multi voltage capable for optimum brightness in 12 and 24 Volt systems. LED modules are polarity conscious. Reverse polarity will not damage this product but will inhibit its function. HELLA recommends wire connections be soldered, and heat shrink tubing applied to seal the joint.

Colour	Connect to	Power Consumption
Black	Earth (-)	-
Red	Positive (+)	0.5 W

NB: Lamp must be protected by a fuse rated at 2 amperes maximum.

Compatibility to existing electrical systems

It is important for the installer to ascertain the compatibility of the low power consumption LED lamps with the electrical and/or electronic systems of the complete vehicle, including trailers. In most cases the reduced power consumption is beneficial by imposing less demands on the entire electrical system.

For certain functions some electrical systems rely on a set power consumption for monitoring whether, for example, a trailer is connected.

Operation of this lamp using alternating current or modulated direct voltage will cause premature light failure. HELLA recommends connecting ADR or ECE certified Multivolt LED signal and marker lamps to a continuous (unmodulated) 12V or 24V power supply to ensure safe light operation.

FIT AND FORGET - BY DESIGN

Congratulations, the product you have selected comes from **HELLA** - a world leader in LED lighting design.

Following the launch of the first LED automotive signal lamps in 1990, **HELLA** Design and Innovation continues to set new standards. **HELLA** innovative solutions have been incorporated into millions of lamps, engineered and tested to the most stringent standards, to suit the most demanding environmental conditions.

The cornerstone to the success of our products is our no compromise **Fit and Forget - by Design** philosophy which is incorporated into every step of the product life cycle.

In a world consuming finite resources at an ever faster rate, **Fit and Forget - by Design** is the right environmental choice that also makes perfect economic sense to customers that consider the total life cycle Cost of Ownership.

For general comments about HELLA's products please contact us on E-mail at techfeedback@hella.co.nz

