



**ADR - APPLICATION AND MOUNTING  
INSTRUCTIONS**  
**ADR 74/00 SIDE MARKER LAMP**  
**ADR 45/01 SIDE MARKER LAMP** (Pre 18/11/2017 Compliance Date)

This Side Marker Lamp, identified by lens marking 9700 and the  logo was manufactured to comply with ADR 74/00 & ADR 45/01 Side Marker Lamps.

**LAMP MAY BE MOUNTED AS FOLLOWS:**

- Lamp mounting surface must be vertical to the ground.
- Lamp reference axis must be square to the vehicle longitudinal axis.
- Lamp centre line must be horizontally oriented, with lamp's red side facing rearward  
(Note: cable exit is red side)

**ADR 13/00 INSTALLATION REQUIREMENTS**

- A tolerance of +/-3° applies on all mounting details.
- Geometric visibility:  
Vertical: From 10° above and below the horizontal  
Horizontal: From 5° out to 85° out at the front and the rear

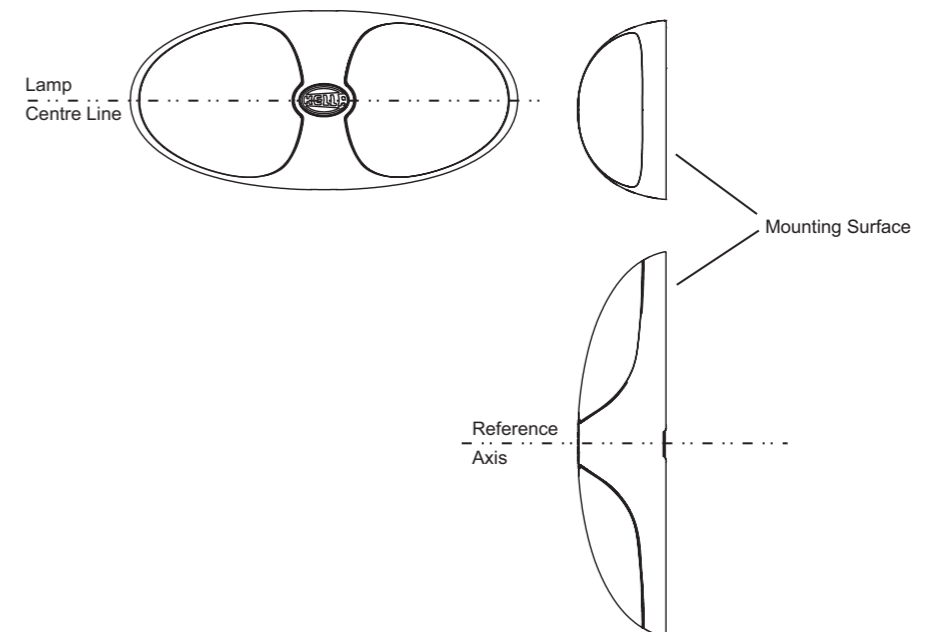

Note: Please refer to ADR 13/00 for more details.

PART NUMBER	CTA NUMBER	ADR 51/00 GLOBE	LENS IDENTIFICATION NO.
2033 2PS 959 700-2xx 959.700-2xx	CTA-031432	N/A LED	9700

**HELLA-New Zealand Limited, Auckland, New Zealand**

INSTRUCTION SHEET  
for: **2PS 959 700-2xx / 2033**



**Lamp Mounting**

Do not mount the lamp where damage is likely to be sustained due to tie-downs and other securing devices.

Lamp should be mounted on a flat surface. Drill two 6mm diameter holes at 47mm centres.

5mm diameter screws or bolts are recommended to mount the lamp using the mounting bushes provided.

If passing the cable through a hole, ensure there are no sharp edges to cut or chafe the cable.

Drill a cable exit hole 6mm diameter in the position as shown on diagram below.

Connect lamp wiring as per chart below.

Try to keep the cable as long as possible, preferably join the cable inside a sealed cable junction box.

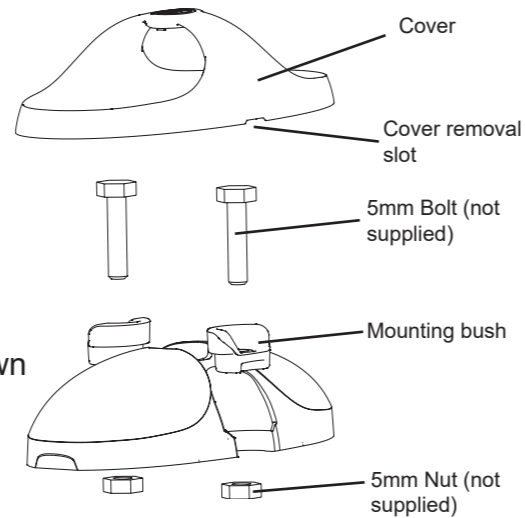

**General Dimensions (mm)**

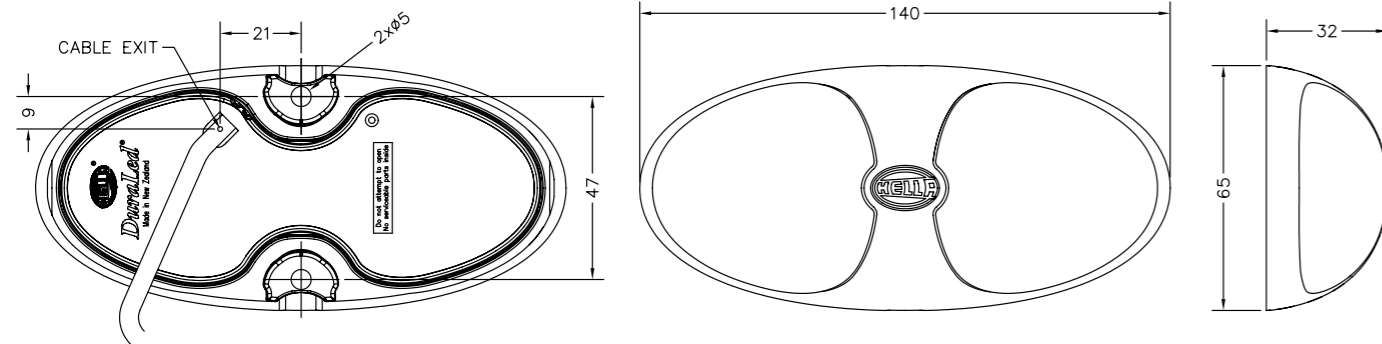

**Wiring Colour Coding**

This lamp is Multivolt capable allowing full light output between 9 and 33 volts.

LED modules are polarity conscious. Reverse polarity will not damage this product but will inhibit its function.

HELLA recommends wire connections be soldered, and heat shrink tubing applied to seal the joint.

Colour	Connect to	Power Consumption
Red	Signal (+)	3W
Black	Negative (-)	-

**NB:** Lamp must be protected by a fuse rated at 5 amperes maximum.

**Important Notes for Installer and Vehicle Owner**



**Introduction**

Multivolt LED signal and marker lamps offer many advantages over conventional bulb lamps. Significantly reduced power consumption, ultra long life and high tolerance to shock and vibration make the LED lamps the ideal choice for the commercial transport industry, where the cost of ownership versus the initial purchase price of the product is well understood.

**Compatibility to existing electrical systems**

It is important for the installer to ascertain the compatibility of the low power consumption LED lamps with the electrical and/or electronic systems of the complete vehicle, including trailers. In most cases the reduced power consumption is beneficial by imposing less demands on the entire electrical system.

For certain functions some electrical systems rely on a set power consumption for monitoring whether, for example, a trailer is connected.

Operation of this lamp using alternating current or modulated direct voltage will cause premature light failure. HELLA recommends connecting ADR or ECE certified Multivolt LED signal and marker lamps to a continuous (unmodulated) 12V or 24V power supply to ensure safe light operation.

**Electromagnetic Compatibility (EMC)**

Multivolt LED lamps are electronic devices. The electrical circuits contain components that suppress possible interference, both emission as well as susceptibility, to the technical requirements for the application of the Regulatory Compliance Mark (RCM).

To avoid false signals or interference, it is standard practice that sensitive instrumentation such as ABS and Tachometers etc. are provided with direct earths.

**Protection against damage due to voltage spikes**

This Multivolt LED lamp is protected against damage from positive voltage spikes caused by events such as load dump conditions up to severity level 3 of ISO 7637-2 and contains a Transient Voltage Suppressor (TVS) designed to withstand a pulse of up to 5000 Watts.

The lamp is protected against reverse polarity connection and negative voltage spikes of up to 1000 volts.

**Electric Welding**

Electric Welding may damage the LED lamps. For LED lamps, HELLA recommends the negative connection to be wired isolated from the vehicle chassis. If the lamp uses the chassis as the earth return it is recommended that this earth return is disconnected during electric welding.

**Warranty Statement**

**Congratulations!** The product you have selected comes from HELLA - one of the world's leading manufacturers of lighting products. The product comes with a Lifetime Warranty covering faults in materials, components or workmanship.

In the unlikely event that you should experience a confirmed warranty related problem with your purchase, HELLA will, at its discretion, either repair or replace the product or refund the purchase price.

Warranty services may be obtained by returning the product within the warranty period to the HELLA Dealer where the product was originally purchased. This warranty is in addition to and does not preclude any other rights or remedies available to the consumer under any local legislation related to the provision of goods or services.

Our goods come with guarantees that cannot be excluded under the Australian Consumer Law. You are entitled to a replacement or refund for a major failure and for compensation for any other reasonably foreseeable loss or damage. You are also entitled to have the goods repaired or replaced if the goods fail to be of acceptable quality and the failure does not amount to a major failure.

Lifetime means the economic life of the vehicle these products were first installed on.

This warranty does not cover:

- 1.) Claim/s as a result of normal wear and tear or of any modifications, alterations non-compliance of assembly, service and operating instructions and/or any unfit or improper use.
- 2.) Any expenses incurred in the process of making the claim.

Note: For lamps sold in Australia warranty services are provided by HELLA Australia Pty. Ltd., 4 Hargrave Place, P.O. Box 89, Mentone, Victoria, 3194 Australia. Customer Service 1800 061 729 email: [custservice@hella.com](mailto:custservice@hella.com) [https://www.hella.com/hella-au/assets/media\\_global/IAM\\_Statement\\_of\\_Warranty.pdf](https://www.hella.com/hella-au/assets/media_global/IAM_Statement_of_Warranty.pdf)

For general comments about HELLA's products please contact us on E-mail at: [techfeedback@hella.co.nz](mailto:techfeedback@hella.co.nz)