



**ADR - APPLICATION AND MOUNTING INSTRUCTIONS**

**Designline LED Multivolt (9 - 33 VOLT) MODULE  
HIGH PERFORMANCE REVERSING LAMP**

This **Multivolt** LED module is designed to be retro-fitted to Designline series lamps, HELLA Part Numbers 2041, 2424, 2424LED-x and 2428-x

This **Multivolt** LED modules are designed to operate on input voltages from 9 - 33 volts.

**Lens Marking and ADR 13/00 Installation Requirements**

This lamp identified by lens marking HNZ 9040 and the  logo, was manufactured to comply with: ADR 1/00 Reversing Lamps

- A tolerance of +/-3° applies on all mounting details.
- Lamp mounting surface must be vertical to the ground
- Lamp module reference axis must be parallel to the vehicle longitudinal axis
- Lamp must be visible from 45° inboard and 45° outboard, as well as from 10° above and to 5° below the horizontal axis.
- Lamp module centre line must be horizontal to the ground.
- Lamp is approved to be mounted only with lens engraving "TOP" located correctly.

Please refer to ADR 13/00 for more details.

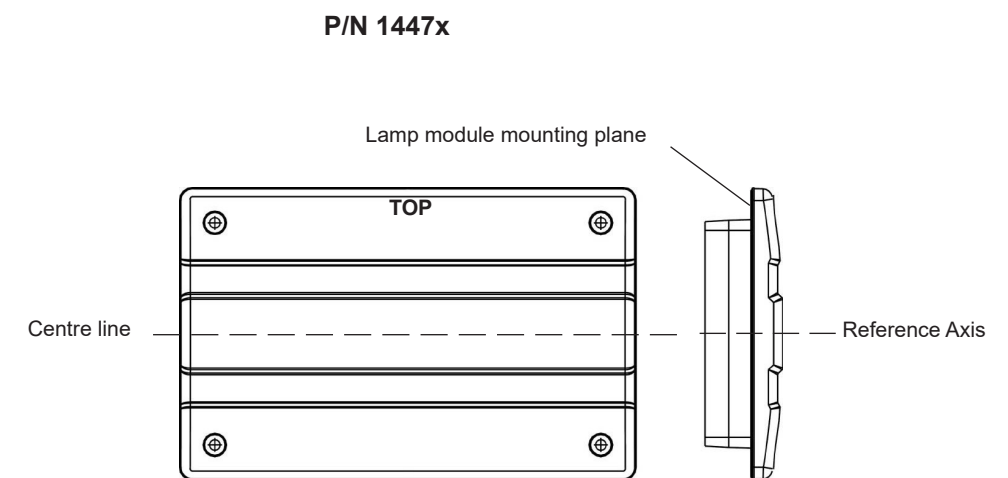

PART NUMBER	CTA NUMBER	ADR 51/00 GLOBE	LENS IDENTIFICATION NO.
1447 2ZR 959.041-3xx 959.041-3xx	CTA-045662	N/A LED	9040



### Lamp Module Mounting Instructions

- Remove existing lamp or lens, bulb holder and hardware from housing.
- Connect cable inside existing lamp housing as per chart below.  
**NB:** HELLA recommends wire connections be soldered, and heat shrink tubing applied to seal the joint.
- Ensure housing drain hole is clear.
- Ensure there are no sharp edges to cut or chafe the cable.
- Test all lamp functions.
- Mount module into lamp housing with new gasket and existing screws, and fit screw caps.

**Please note: This lamp contains a patented hydrophobic breathing system to equalise air pressure inside the lamp. The module is sealed against moisture and dust but not designed for prolonged submersion.**

### Wiring Colour Coding

Note: Lamp is polarity conscious. The reversal of the polarity will not damage this product but will inhibit its function.

Colour	Connect to	Power Consumption
White	Earth (-)	-
Grey	Reverse (+)	7 watts

### ***FIT AND FORGET - BY DESIGN***

Congratulations, the product you have selected comes from **HELLA** - a world leader in LED lighting design.



Following the launch of the first LED automotive signal lamps in 1990, **HELLA** Design and Innovation continues to set new standards. **HELLA** innovative solutions have been incorporated into millions of lamps, engineered and tested to the most stringent standards, to suit the most demanding environmental conditions.

The cornerstone to the success of our products is our no compromise **Fit and Forget - by Design** philosophy which is incorporated into every step of the product life cycle.

In a world consuming finite resources at an ever faster rate, **Fit and Forget - by Design** is the right environmental choice that also makes perfect economic sense to customers that consider the total life cycle Cost of Ownership.

For general comments about HELLA's products please contact us on E-mail at [techfeedback@hella.co.nz](mailto:techfeedback@hella.co.nz)

## Important Notes for Installer and Vehicle Owner



### Introduction

Multivolt LED signal and marker lamps offer many advantages over conventional bulb lamps. Significantly reduced power consumption, ultra long life and high tolerance to shock and vibration make LED lamps the ideal choice for the commercial transport industry, where the cost of ownership versus the initial purchase price of the product is well understood.

### Compatibility to existing electrical systems

It is important for the installer to ascertain the compatibility of the low power consumption LED lamps with the electrical and/or electronic systems of the complete vehicle, including trailers. In most cases the reduced power consumption is beneficial by imposing less demands on the entire electrical system.

For certain functions some electrical systems rely on a set power consumption for monitoring whether, for example, a trailer is connected.

Operation of this lamp using alternating current or modulated direct voltage will cause premature light failure. HELLA recommends connecting ADR or ECE certified Multivolt LED signal and marker lamps to a continuous (unmodulated) 12V or 24V power supply to ensure safe light operation.

### Electromagnetic Compatibility (EMC)

This Multivolt LED lamp is an electronic device. The electrical circuits contain components that suppress possible interference, both emission as well as susceptibility, to the technical requirements for the application of the Regulatory Compliance Mark (RCM).

To avoid false signals or interference, it is standard practice that sensitive instrumentation such as ABS and Tachometers etc. are provided with direct earths.

### Protection against damage due to voltage spikes

This Multivolt LED lamp is protected against damage from positive voltage spikes caused by events such as load dump conditions specified in ISO 7637 and contains a Transient Voltage Suppressor (TVS) designed to withstand a pulse of up to 5000 Watts.

The lamp is protected against reverse polarity connection and negative voltage spikes of up to 1000 volts.

### Electric Welding

Electric Welding may damage the LED lamps. For LED lamps, HELLA recommends the negative connection to be wired isolated from the vehicle chassis. If the lamp uses the chassis as the earth return it is recommended that this earth return is disconnected during electric welding.