

## Important Notes for Installer and Vehicle Owner



### Introduction

Multivolt LED signal and marker lamps offer many advantages over conventional bulb lamps. Significantly reduced power consumption, ultra long life and high tolerance to shock and vibration make LED lamps the ideal choice for the commercial transport industry, where the cost of ownership versus the initial purchase price of the product is well understood.

### 24V DC ISO 13207-1 Compliant Direction Indicator Lamp Monitoring with the Patented HCS (HELLA Compatibility Solution) Technology

On vehicles being driven on public roads the operation of the Direction Indicator Lamps must be monitored and a fault must be instantly signalled to the driver. Direction Indicator Lamps are an important road safety feature signalling the direction change intention of the driver. Failure to signal or failure to recognise a direction indicator represents a significant cause for road accidents.

In many countries, LED direction indicator lamps offering a reliable 'Fit and Forget' solution, have become the retrofit item of choice for the cost conscious transport operator. LED lamps, with much lower power consumption and Multivolt features, are often a challenge for existing failure detection control electronics of modern trucks and buses. Transport fleets often feature a mixture of trailer units equipped with either bulb or LED based Direction Indicator Lamps. Each of these trailer units ideally must be freely interchangeable with any of the tractor units in the fleet.

Some manufacturers recommend to fit additional resistive loads in parallel to the LED lamps to simulate the 21 watts consumed by a bulb lamp. Such pure resistive load solutions can be problematic for the following reasons:

- They mask the possible failure of the actual LED Indicator Lamp itself.
- In many cases such pure resistive solutions do not function since they only provide a linear time/current response which is significantly different to the time/current response of a bulb filament when it heats up.
- They consume a lot of energy and thus eliminate the desired lower power advantage of an LED lamp.

### Safe conversion to LED Direction Indicator Lamps is now possible with the patented HCS HELLA Compatibility Solution.

HELLA supplies electronic control and flasher units which make it possible to convert the indicator failure system for various vehicles. This is necessary if the vehicle manufacturer does not guarantee indicator bulb failure control via the vehicle wiring system. HCS has been patented by HELLA.

### HCS Direction Indicator Lamps work in conjunction with HCS / ISO 13207-1 compliant failure detection systems at 24V DC. If additional lamps are fitted beyond the amount supported by the HCS / ISO 13207-1 compliant failure detection system then they must be wired separately so as not to be detected.

For further information about HCS please refer to the latest HELLA catalogue or the HELLA New Zealand web site, [www.hella.co.nz](http://www.hella.co.nz)

### Compatibility to existing electrical systems

It is important for the installer to ascertain the compatibility of the low power consumption LED lamps with the electrical and/or electronic systems of the complete vehicle, including trailers. In most cases the reduced power consumption is beneficial by imposing less demands on the entire electrical system.

For certain functions some electrical systems rely on a set power consumption for monitoring whether, for example, a trailer is connected.

Operation of this lamp using alternating current or modulated direct voltage will cause premature light failure. HELLA recommends connecting ADR or ECE certified Multivolt LED signal and marker lamps to a continuous (unmodulated) 12V or 24V power supply to ensure safe light operation.

### Electromagnetic Compatibility (EMC)

This Multivolt LED lamp is an electronic device. The electrical circuits contain components that suppress possible interference, both emission as well as susceptibility, to the technical requirements for the application of the Regulatory Compliance Mark (RCM).

To avoid false signals or interference, it is standard practice that sensitive instrumentation such as ABS and Tachometers etc. are provided with direct earths.

### Protection against damage due to voltage spikes

This Multivolt LED lamp is protected against damage from positive voltage spikes caused by events such as load dump conditions specified in ISO 7637 and contains a Transient Voltage Suppressor (TVS) designed to withstand a pulse of up to 5000 Watts.

The lamp is protected against reverse polarity connection and negative voltage spikes of up to 1000 volts.

### Electric Welding

Electric Welding may damage the LED lamps. For LED lamps, HELLA recommends the negative connection to be wired isolated from the vehicle chassis. If the lamp uses the chassis as the earth return it is recommended that this earth return is disconnected during electric welding.

## INSTRUCTION SHEET

for: **2VP 980 761-951 / 2431-DTCS**



## ADR - APPLICATION AND MOUNTING INSTRUCTIONS

### JUMBO-S LED TRIPLE MODULE LAMP WITH HCS

Stop, Rear Position, Rear Direction Indicator, Reverse Lamp with Retro Reflector  
Multivolt (Suitable for 12 and 24 volt systems)

### Lens Marking and ADR 13/00 Installation Requirements

This lamp identified by lens marking 0760 and the HELLA logo, was manufactured to comply with:

ADR 1/00 Reversing Lamps

ADR 6/00 Cat 2a Rear Direction Indicator Lamps

ADR 47/00 Retro Reflectors

ADR 49/00 Rear Position (Side) / Stop Lamps

- A tolerance of  $\pm 3^\circ$  applies on all mounting details.
- Lamp mounting surface must be vertical to the ground, and at right angles to the longitudinal axis of the vehicle.
- Lamp must be visible from  $45^\circ$  inboard and  $80^\circ$  outboard, as well as from  $15^\circ$  above and below the horizontal axis.
- Lamp is approved to be mounted horizontally and vertically.

Please refer to ADR 13/00 for more details.

Side View

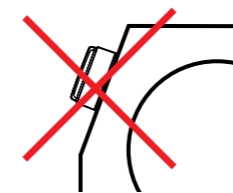

Rear View

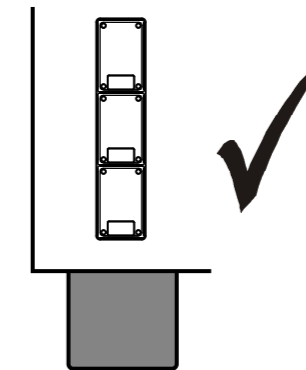

Top View

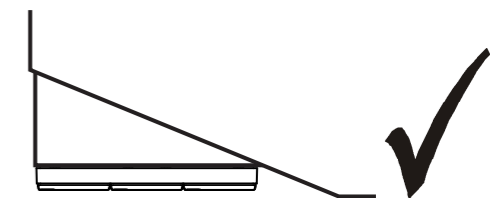
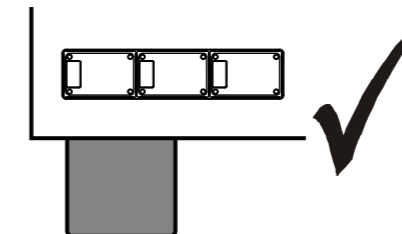
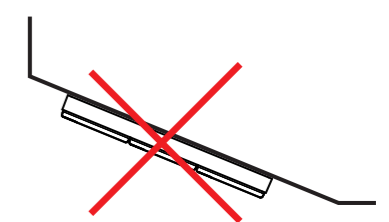

LENS IDENTIFICATION NUMBER: 0760

CATALOGUE NUMBER	ENGINEERING NUMBER	CRN NUMBER	COMPLIANCE NUMBER	ADR 51/00 GLOBE	ADR APPLICABLE
2431-DTCS	980 761-951	45442 45443 45633 45634 / 45632	1461*RV*C 2161*RDI*C 2361*RR*C 2361*ST*C / 2361*RP*C	N/A LED	ADR 1/00 ADR 6/00 ADR 47/00 ADR 49/00
AMENDMENTS				ADR COMPLIANCE VERIFIED	ISSUE DATE:
					10/2013
					460 965-20

HELLA-New Zealand Limited, Auckland



### Lamp Mounting Instruction

#### Installation of the Bolt Retainers (x2)

- Step 1. Insert the Hex Head Bolt into the Red Bolt Retainer.  
Step 2. Push the Hex Head Bolt until it is flush with the top of the Red Bolt Retainer.  
Step 3. Guide the fork end of the Red Bolt Retainer into the backplate pocket of the lamp.

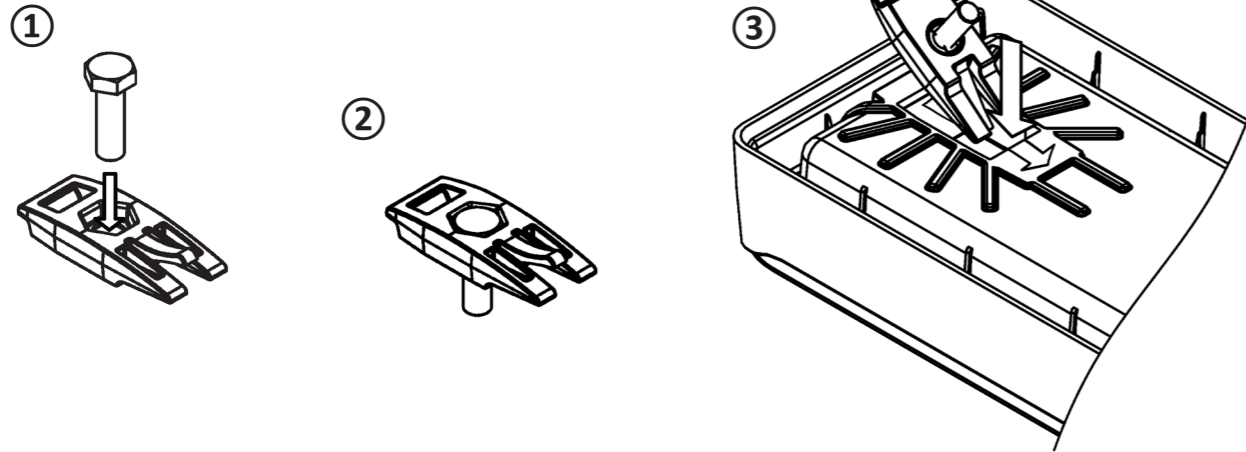

- Step 4. Hold the threaded end of the Hex Head Bolt and push the Red Bolt Retainer down at an angle towards the far end of backplate pocket. The Red Bolt Retainer should then slide fully into the backplate pocket.  
Step 5. Using the threaded end of the Hex Head Bolt pull the Red Bolt Retainer back towards the end of the lamp until it clicks into its final position.

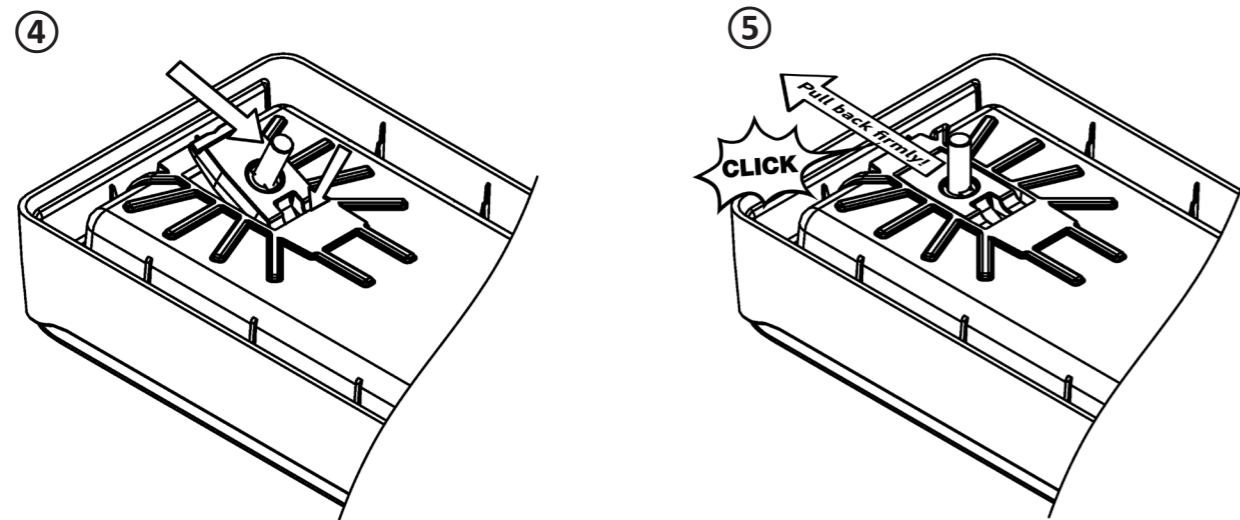

#### Surface Mounting

- Lamp should be mounted on a flat surface and as close as possible to the outer extremities of the vehicle. Refer to the front page for mounting restrictions.
- Determine a suitable location for the lamp and drill two Ø8.5 mm holes through the mounting surface according to the hole centre dimensions (as per drawing on the next page).
- A minimum rectangular hole size of 48mm x 68mm is required for the Deutsch 6-way socket in the backplate.
- Prepare the lamp cable (not supplied) using the connect plug connector (Deutsch P/N DT06-6S, wedge (Deutsch P/N W6S and terminals (Deutsch P/N 0462-201-16141. These Deutsch parts can be purchased separately as a kit (HELLA P/N 4963-P).
- If water can collect at the back of the lamp, ensure that there are sufficient exits for it to drain out.
- Secure the lamp to the mounting surface by tightening the two mounting nuts supplied with the lamp.



### Lamp Mounting Instruction

#### Wiring Procedure

- Disconnect the earth cable from vehicle battery before attempting any electrical work or connections. Failure to do so could result in damage to vehicle and/or an electrical fire.
- Try to keep the cables as long as possible, preferably join the cable inside a sealed cable junction box.
- Connect the cables as per the table below and test that the lamp functions correctly.

#### General Dimensions (in millimetres)

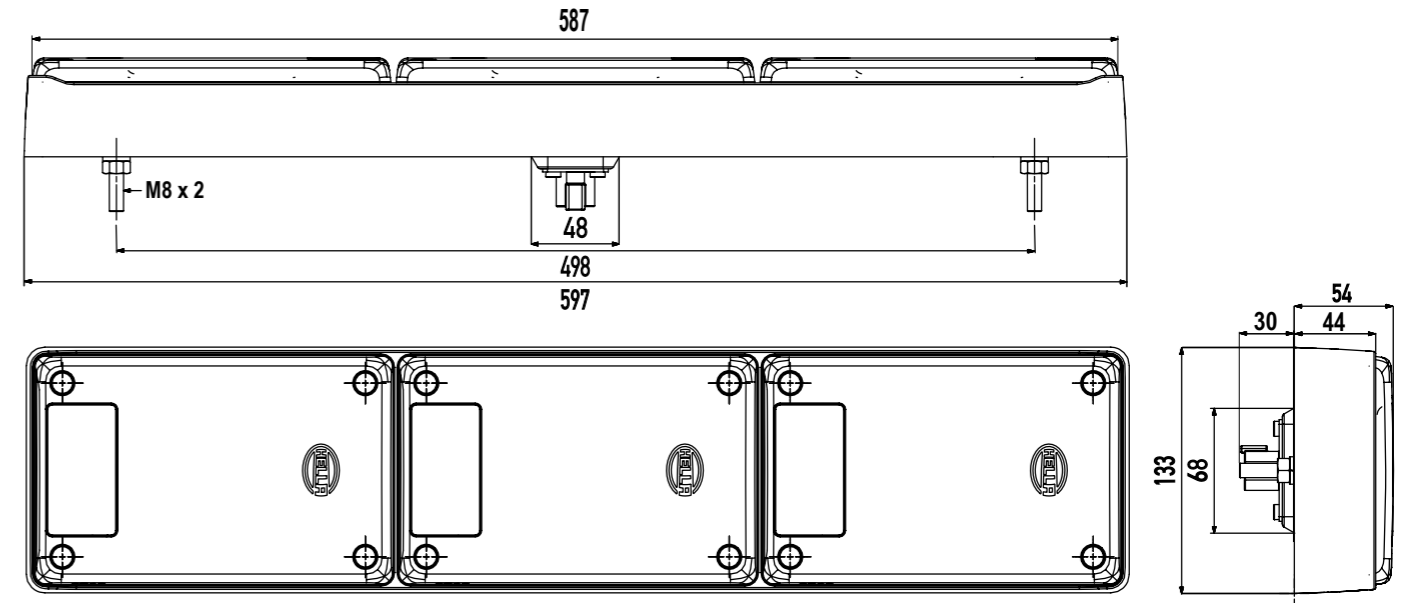

#### Wiring Colour Coding

Lamp is polarity conscious. The reversal of the polarity will not damage this product but will inhibit its function. HELLA recommends wire connections be soldered, and heat shrink tubing applied to seal the joint.

Pin Number	Connect to	Power Consumption
1	Rear Position (+)	1 watt
2	Stop (+)	5 watts
3	Indicator & ISO 13207-1 Pulse (+)	4 watts
4	Reverse (+)	4 watts
5	Earth (-)	-
6	-	-

**NB:** Lamp must be protected by a fuse rated at 5 amperes maximum.

### FIT AND FORGET - BY DESIGN



Congratulations, the product you have selected comes from **HELLA** - a world leader in LED lighting design.

Following the launch of the first LED automotive signal lamps in 1990, **HELLA** Design and Innovation continues to set new standards. **HELLA** innovative solutions have been incorporated into millions of lamps, engineered and tested to the most stringent standards, to suit the most demanding environmental conditions.

The cornerstone to the success of our products is our no compromise **Fit and Forget - by Design** philosophy which is incorporated into every step of the product life cycle.

In a world consuming finite resources at an ever faster rate, **Fit and Forget - by Design** is the right environmental choice that also makes perfect economic sense to customers that consider the total life cycle Cost of Ownership.

For general comments about Hella's products please contact us on E-mail at [techfeedback@hella.co.nz](mailto:techfeedback@hella.co.nz)