



INSTRUCTION SHEET  
for: **2BE 980 690-0xx / 2108-GMD24V**

**APPLICATION AND MOUNTING INSTRUCTIONS**

**83mm ROUND LED DRL / FRONT INDICATOR / FRONT POSITION LAMP  
24V DC**

**Features**

- 25 LED design
- Low power consumption
- Reverse polarity protected
- Built-in spike protection
- Ultra long service life
- Fully sealed against dust and water
- Withstands most vibration and mechanical shock applications
- Manufactured from the latest "high tech" lens material with enhanced impact and chemical tolerance
- Flush mount for low profile appearance

**Lens Marking and Installation Requirements**

This DRL / Front Indicator / Front Position Lamp, identified by lens marking **E24** 5854 and the **HELLA** logo, was manufactured to comply with:

- ECE Regulation 6 Category 1 for Front Direction Indicator Lamps
- ECE Regulation 7 for Front Position (side) Lamps
- ECE Regulation 87 for Daytime Running Lamps

- Lamp mounting surface must be vertical to the ground, and at right angles to the longitudinal axis of the vehicle.
- Lamp must be visible from 45° inboard and 80° outboard, as well as from 15° above and below the horizontal axis.
- Lamps must be mounted no less than 350 mm and no more than 1500 mm above the ground.
- Lamps to be mounted within 400 mm of the widest point of the vehicle and no closer than 600 mm together.
- Lamp is approved to be mounted only with lens engraving "TOP" located correctly.

**Front View**

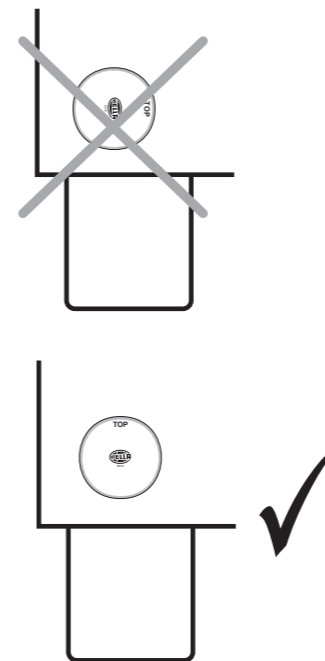

**Top View**



**Side View**

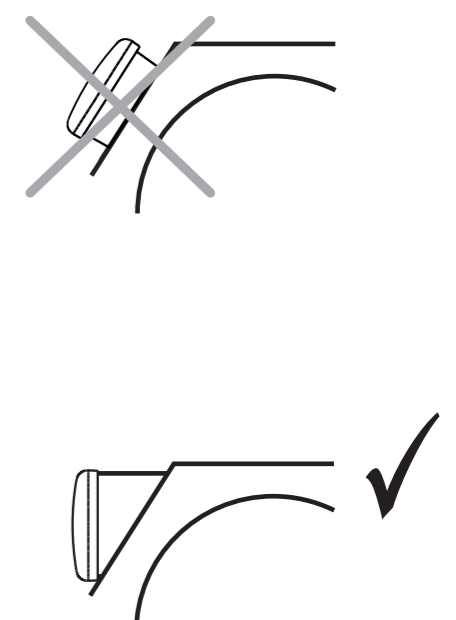

HELLA New Zealand

**Mounting Instruction**  
Anbauanweisung

HKG-LIK Ke  
31485  
07.01.2010

Type: **2BE 980 690**

Page 1 / Seite 1

Belongs to approval no.: **E24 5854**

Gehört zu Gen.-Nr.:

**Daytime Running Lamp and / or Front Position Lamp and / or Direction Indicator**  
optionaly grouped for Automobile.  
Tagfahrleuchte und / oder Begrenzungsleuchte und / oder Fahrtrichtungsanzeiger  
wahlweise zusammengebaud für Kraftfahrzeuge.

Light source(s): Lichtquelle(n):	Design voltage: Prüfspannung:	Nominal voltage: Nennspannung:	Nominal power: Nennleistung:
Daytime Running Lamp	12 LED 28.0V	24.0V	4.0W
Tagfahrleuchte	1 LED 28.0V	24.0V	1.0W
Front Position Lamp	12 LED 28.0V	24.0V	4.0W
Begrenzungsleuchte			
Direction Indicator			
Fahrtrichtungsanzeiger			

☒ = Centre of reference in accordance with the ECE-Regulations - No. 6, 7, 87.  
Bezugspunkt nach den ECE-Regelungen - Nr. 6, 7, 87.

☑ = Centre of reference for the definition for illuminating surface in accordance with the Council Directive 76/756 EEC or ECE-Regulation No. 48 (see Annex A).  
Bezugspunkt zur Bestimmung der Grenzen der leuchtenden Fläche nach 76/756 EWG bzw. ECE-Regelung Nr. 48.

Axis of reference: Parallel to the car centre line and parallel to the road.  
Bezugsachse: Parallel zur Fahrzeuglängsachse und parallel zur Fahrbahn.

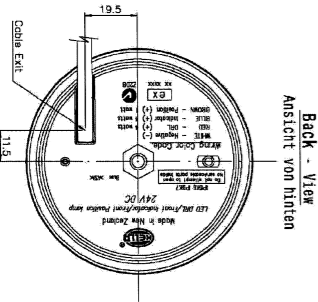
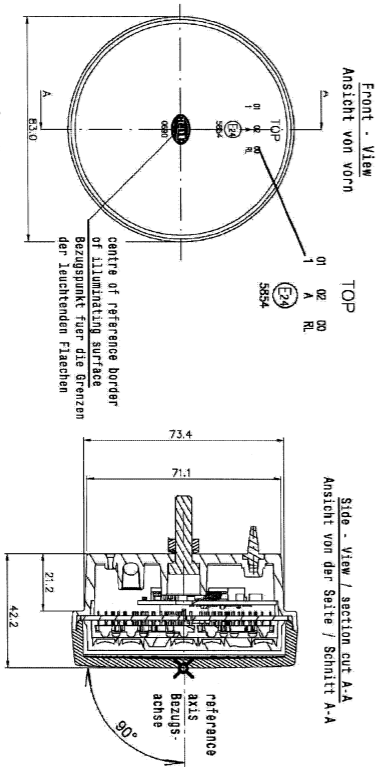

The device must be mounted according to the enclosed fitting documents (e.g. sketch + Annex A).  
Der App.-Zus. Einbau der Geräte hat nach anliegenden An- bzw. Einbauanweisungen (z. B. Skizze und Anlage A) zu erfolgen.



HELLA New Zealand

**Mounting Instruction**  
Anbauanweisung

HKG-LIK Ke  
31485  
07.01.2010

Type: **2BE 980 690**

Page 2 / Seite 2

Belongs to approval no.: **E24 5854**

Gehört zu Gen.-Nr.:

**Daytime Running Lamp and / or Front Position Lamp and / or Direction Indicator**  
optionaly grouped for Automobile.  
Tagfahrleuchte und / oder Begrenzungsleuchte und / oder Fahrtrichtungsanzeiger  
wahlweise zusammengebaud für Kraftfahrzeuge.

Optionally mounted behind a front screen with a transmission at least 85%.  
Wahlweise hinter einer Scheibe verbaut mit einer zulässigen Transmission von mindestens 85%.  
Permissible angle of the front screen:  
Zulässiger Winkel der Scheibe:  
 $\alpha$  1, 2 = up to / bis 115°  
 $\beta$  1, 2 = up to / bis 115°

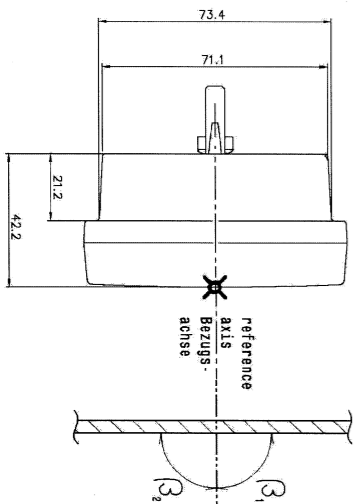
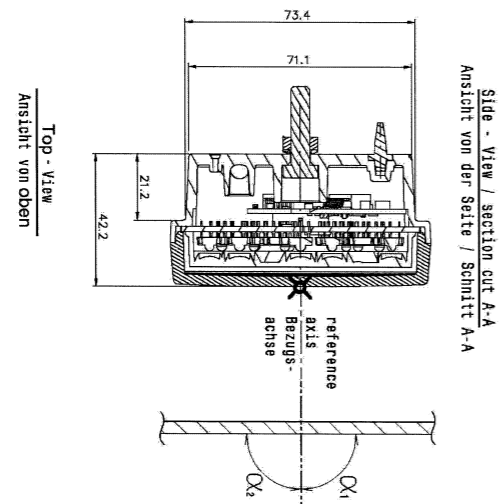

The device must be mounted according to the enclosed fitting documents (e.g. sketch + Annex A).  
Der App.-Zus. Einbau der Geräte hat nach anliegenden An- bzw. Einbauanweisungen (z. B. Skizze und Anlage A) zu erfolgen.



### Lamp Mounting

1/4" UNC Nut, bolt and washer have been supplied with this product.

Lamp should be mounted on a flat surface. Drill one mounting hole between 6.5mm and 8mm in diameter. A small 5mm location hole is also recommended to assist in mounting the lamp accurately and to stop the lamp from rotating during or after installation. This can be done using the supplied location pin.

If passing the cable through a hole, ensure there are no sharp edges to cut or chafe the cable.

Drill a cable exit hole 6mm diameter in the position as shown on diagram below.

Ensure the lens engraving "TOP" is located correctly.

Connect lamp wiring as per chart below.

Try to keep the cable as long as possible, preferably join the cable inside a sealed cable junction box.

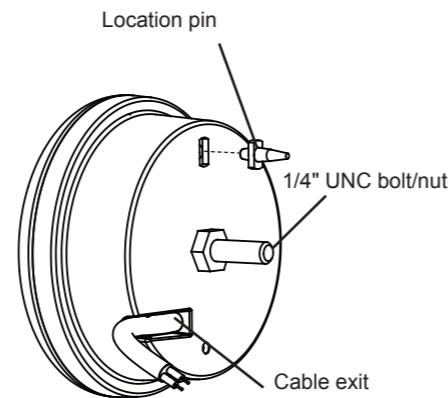

### General Dimensions (mm)

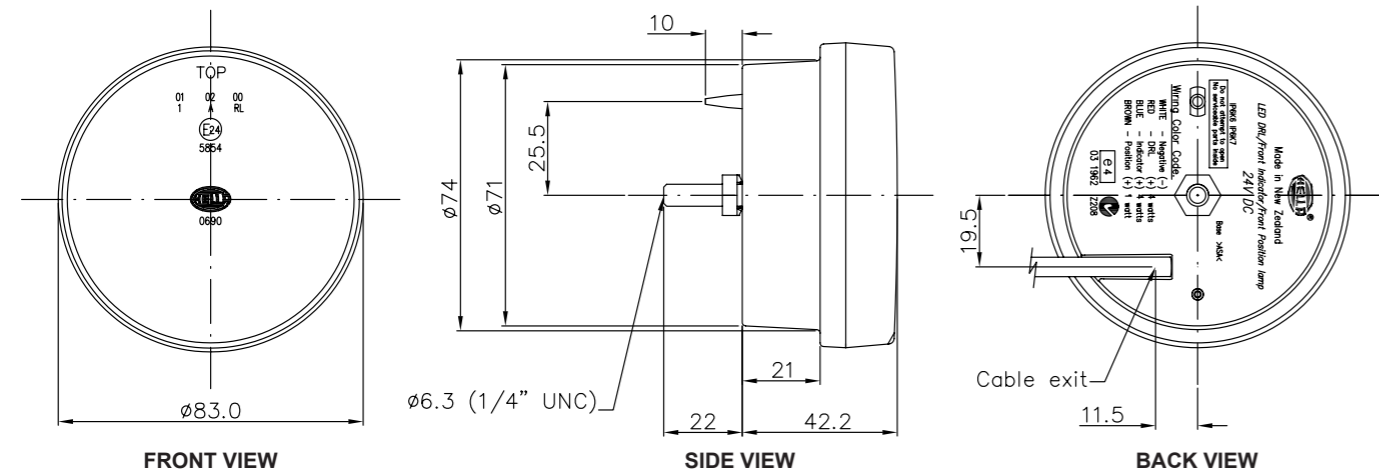

### Wiring Colour Coding

This lamp is for 24 volt applications only.

LED modules are polarity conscious. Reverse polarity will not damage this product but will inhibit its function.

HELLA recommends wire connections be soldered, and heat shrink tubing applied to seal the joint.

Colour	Connect to	Power Consumption	DRL Operation Logic
White	Negative (-)	-	-
Red	DRL (+)	4 watts	-
Blue	Front Indicator (+)	4 watts	DRL will switch OFF when indicator function is operating
Brown	Front Position (+)	1 watt	DRL will switch OFF when position function is operating

**NB:** Lamp must be protected by a fuse rated at 5 amperes maximum.

## Important Notes for Installer and Vehicle Owner



### Introduction

LED signal and marker lamps offer many advantages over conventional bulb lamps. Significantly reduced power consumption, ultra long life and high tolerance to shock and vibration make the LED lamps the ideal choice for the commercial transport industry, where the cost of ownership versus the initial purchase price of the product is well understood.

### Daytime Running Lamps

Daytime running lamps are not a substitute for dipped beam headlights at dusk/dawn or during darkness. It is important for the installer to check that the daytime running lamps illuminate only when the vehicle lighting is switched OFF and the ignition is switched ON.

### Compatibility to existing electrical systems

It is important for the installer to ascertain the compatibility of the low power consumption LED lamps with the electrical and/or electronic systems of the complete vehicle, including trailers. In most cases the reduced power consumption is beneficial by imposing less demands on the entire electrical system.

For certain functions some electrical systems rely on a set power consumption for monitoring whether, for example, an indicator globe has failed or a trailer is connected.

Operation of this lamp using alternating current or modulated direct voltage will cause premature light failure. HELLA recommends connecting ADR or ECE certified LED signal and marker lamps to a continuous (unmodulated) 24V power supply to ensure safe light operation.

### Electromagnetic Compatibility (EMC)

This LED lamp is an electronic device. The electrical circuits contain components that suppress possible interference, both emission as well as susceptibility, to the technical requirements for the application of the Regulatory Compliance Mark (RCM). Additionally the electrical circuits conform to the limits prescribed in UNECE Vehicle Regulation No. 10.

To avoid false signals or interference, it is standard practice that sensitive instrumentation such as ABS and Tachometers etc. are provided with direct earths.

### Protection against damage due to voltage spikes

This LED lamp is protected against damage from positive voltage spikes caused by events such as load dump conditions specified in ISO 7637-2.

The lamp is protected against reverse polarity connection and negative voltage spikes of up to 1000 volts.

### Electric Welding

Electric Welding may damage the LED lamps. For LED lamps, HELLA recommends the negative connection to be wired isolated from the vehicle chassis. If the lamp uses the chassis as the earth return it is recommended that this earth return is disconnected during electric welding.

## FIT AND FORGET - BY DESIGN

Congratulations, the product you have selected comes from **HELLA** - a world leader in LED lighting design.



Following the launch of the first LED automotive signal lamps in 1990, **HELLA** Design and Innovation continues to set new standards. **HELLA** innovative solutions have been incorporated into millions of lamps, engineered and tested to the most stringent standards, to suit the most demanding environmental conditions.

The cornerstone to the success of our products is our no compromise **Fit and Forget - by Design** philosophy which is incorporated into every step of the product life cycle.

In a world consuming finite resources at an ever faster rate, **Fit and Forget - by Design** is the right environmental choice that also makes perfect economic sense to customers that consider the total life cycle Cost of Ownership.

For general comments about HELLA's products please contact us on E-mail at [techfeedback@hella.co.nz](mailto:techfeedback@hella.co.nz)