



INSTRUCTION SHEET  
for: **2BE 959 932-16x / 2132-CS**

**APPLICATION AND MOUNTING INSTRUCTIONS**

**110mm ROUND LED FRONT DIRECTION INDICATOR / POSITION LAMP**  
**Multivolt 9-33V DC**

**Features**

- Ultra long service life
- Ultra fast response time
- Reverse polarity protected
- Fully sealed against dust and water (IP6K6 / IP6K7)
- Compensates for voltage drop on long vehicles
- Low power consumption
- Withstands most vibration and mechanical shock applications
- Manufactured from high impact acrylic to withstand high impact forces

**Lens Marking and Installation Requirements**

This lamp module, identified by lens marking 5851 and the logo was manufactured to comply with ECE Regulation 6 Category 1 for Front Direction Indicator Lamps and ECE Regulation 7 for Front Position Lamps.

- A tolerance of +/-3° applies on all mounting details.
- Lamp module mounting surface must be vertical to the ground.
- Lamp module reference axis must be parallel to the vehicle longitudinal axis.
- Lamp module is approved to be mounted only with lens engraving "TOP" located correctly.
- Lamp module must be visible from 45° inboard and 80° outboard, as well as from 15° above and below the horizontal axis.
- Two lamp modules are required.
- Lamps modules must not be mounted less than 350 mm and more than 1500 mm above the ground.
- Lamp modules must be mounted within 400 mm of the widest point of the vehicle and no closer than 600 mm together.
- Lamp module must be mounted further than 40 mm from the dipped beam headlamp and/or front fog lamp.

Please refer to ECE Regulation 48, for further details.

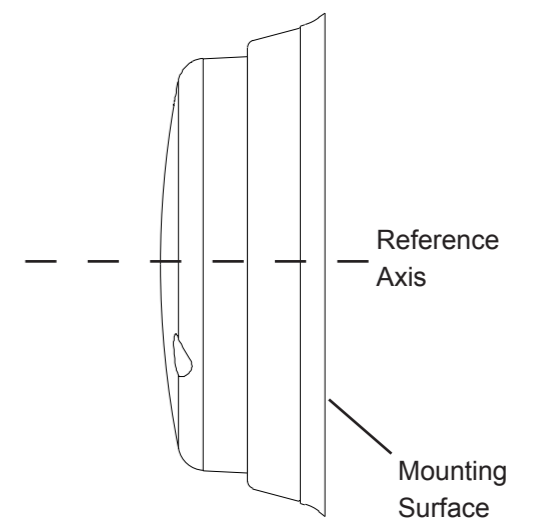
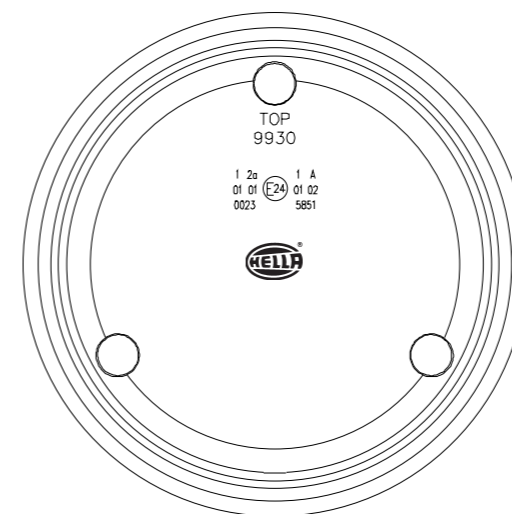

HELLA-New Zealand Limited, Auckland, New Zealand



**Type / Typbezeichnung: 2BE 959 932**

**1 / 2**

Hella New Zealand  
Belongs to approval no: **E24 5851**  
Gehört zur Gen.-Nr.: **E24 5851**

Mounting instruction no:  
Einbauanweisung Nr.: **2BE 959 932**

**Direction Indicator and Front Position Lamp for automobile**  
Fahrlichtungsanzeiger und Begrenzungsleuchte für Kraftfahrzeuge

Function: Funktion:	Light source: Lichtquelle:	Design voltage: Prüfspannung:	Nominal voltage: Nennspannung:	Nominal power: Nennleistung:
Direction Indicator Fahrlichtungsanzeiger	15 LEDs	13.5 / 28.0V	9 - 33V	3.0W
Front Position Lamp Begrenzungsleuchte	1 LED	13.5 / 28.0V	9 - 33V	1.0W

- = Centre of reference in accordance with the ECE-regulation-no. 6 and 7.
- = **Bezugspunkt** nach der ECE-Regelung Nr. 6 und 7.
- = **Centre of reference** for the definition for illuminating surface in accordance with the Council Directive 76/756/EEC or ECE-regulation-No. 48 (see Annex A).
- = **Bezugspunkt** zur Bestimmung der Grenzen der leuchtenden Fläche nach 76/756 EEC oder ECE-Regelung-Nr. 48. Markierung s. auf der Abschluss-Scheibe. Marke s. Anlage A.
- Axis of reference:** Parallel to the car center line and parallel to the road.
- Bezugsachse:** Parallel zur Fahrzeuglängsachse und parallel zur Fahrbahn.

The Direction Indicator has 15 LEDs in one string. If one LED fails than the whole string stops working.  
Der Fahrlichtungsanzeiger beinhaltet 15 LEDs in Reihe geschaltet. Wenn eine LED ausfällt, fällt der gesamte Strang aus.

The device must be surface-mounted or flush-filled according to the enclosed surface-mounting or flush fitting documents (e. g. sketch).  
Der An- bzw. Einbau der Geräte hat nach anliegenden An- bzw. Einbauunterlagen (z. B. Skizze und Anlage A) zu erfolgen.  
**E24 6R-015851** 2009-01-25



**Type / Typbezeichnung: 2BE 959 932**

**2 / 2**

Hella New Zealand  
Belongs to approval no: **E24 5851**  
Gehört zur Gen.-Nr.: **E24 5851**

Mounting instruction no:  
Einbauanweisung Nr.: **2BE 959 932**

**Direction Indicator and Front Position Lamp for automobile**  
Fahrlichtungsanzeiger und Begrenzungsleuchte für Kraftfahrzeuge

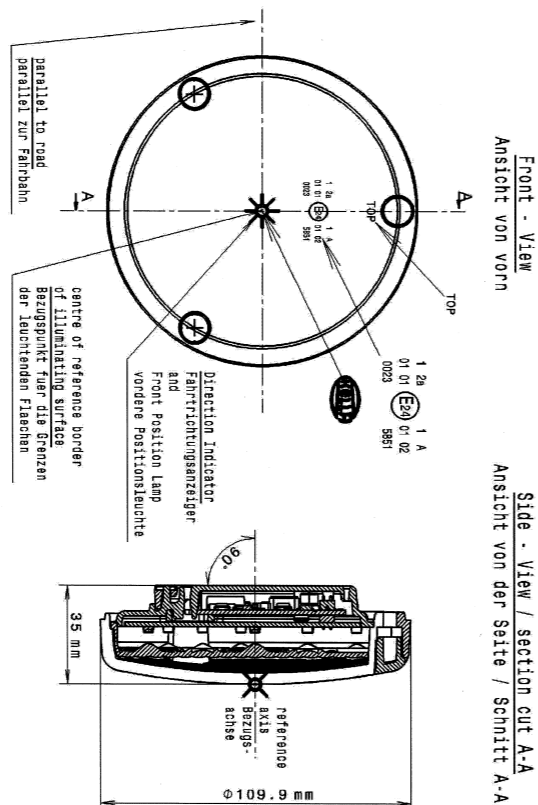

Back-View  
Ansicht von hinten

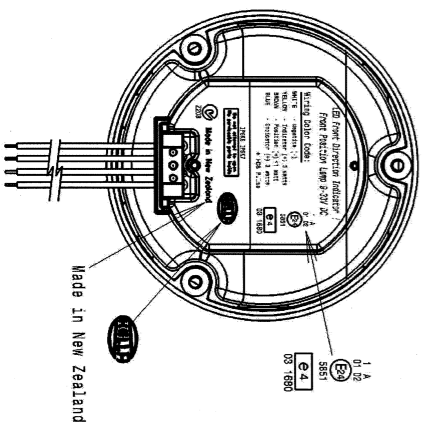

Made in New Zealand

The device must be surface-mounted or flush-filled according to the enclosed surface-mounting or flush fitting documents (e. g. sketch).  
Der An- bzw. Einbau der Geräte hat nach anliegenden An- bzw. Einbauunterlagen (z. B. Skizze und Anlage A) zu erfolgen.  
**E24 6R-015851** 2009-01-25



## Lamp Mounting

### New Installations

- Lamp should be mounted on a flat surface to avoid mounting stress and as shown in the application and mounting instructions.
- Ensure that the engraving "TOP" is located in the correct position.
- After ascertaining the desired position on the vehicle, remove the LED lamp module from the backplate. The backplate can then be used as a template to drill the two screw/bolt mounting points.
- If passing the cables through a hole, ensure there are no sharp edges to cut or chafe the cable.
- Connect the lamp as per the wiring chart shown below, preferably join the cable inside a sealed cable junction box.
- Once the backplate is securely mounted to the vehicle, assemble the LED lamp module to the backplate using the screws and gasket provided.
- Push the screws caps on securely until flush with the lamp surface.

### General Dimensions (mm)

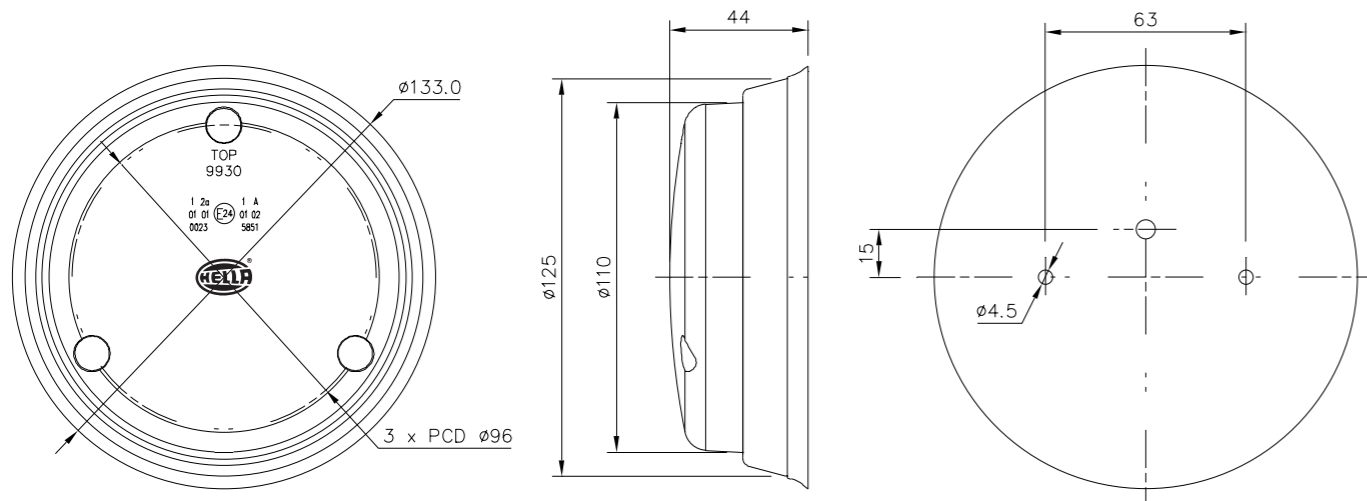

### Wiring Colour Coding

This lamp is multivolt capable allowing full light output between 9 and 33 volts DC. LED lamps are polarity conscious. Reverse polarity will not damage this product but will inhibit its function. HELLA recommends wire connections be soldered, and heat shrink tubing applied to seal the joint.

Colour	Connect to	Power Consumption
White	Negative (-)	-
Yellow	Front Direction Indicator (+)	3 watts
Brown	Front Position (+)	Less than 1 watt
Blue	Front Direction Indicator & HCS Pulse (+)	3 watts

**NB:** Lamp must be protected by a fuse rated at 5 amperes maximum.

**Direction Indicator Lamps with HCS pulse work in conjunction with a failure detection system such as LED flasher units. If additional lamps are fitted beyond the amount supported by the failure detection system than they must be wired separately so as not to be detected.**

## Important Notes for Installer and Vehicle Owner



### Introduction

LED signal and marker lamps offer many advantages over conventional bulb lamps. Significantly reduced power consumption, ultra long life and high tolerance to shock and vibration make the LED lamps the ideal choice for the commercial transport industry, where the cost of ownership versus the initial purchase price of the product is well understood.

### Compatibility to existing electrical systems

It is important for the installer to ascertain the compatibility of the low power consumption LED lamps with the electrical and/or electronic systems of the complete vehicle, including trailers. In most cases the reduced power consumption is beneficial by imposing less demands on the entire electrical system.

For certain functions some electrical systems rely on a set power consumption for monitoring whether, for example, a trailer is connected.

Operation of this lamp using alternating current or modulated direct voltage will cause premature light failure. HELLA recommends connecting ADR or ECE certified Multivolt LED signal and marker lamps to a continuous (unmodulated) 12V or 24V power supply to ensure safe light operation.

### Bulb failure monitoring for indicator lamps

The indicator bulb failure warning (if fitted to the vehicle) relies on the full load of a 21-watt bulb in most cases. Multivolt LED lamps with HCS pulse have integrated electronics for failure checking, if operating correctly the lamp will pulse a resistive load during the flasher "on" cycle to simulate this load.

If the vehicle manufacturer does not guarantee indicator bulb failure control via the vehicle wiring system than HELLA can supply electronic control and flasher units which make it possible to convert the indicator failure system to suit Multivolt LED lamps with HCS pulse.

### Electromagnetic Compatibility (EMC)

This LED lamp is an electronic device. The electrical circuits contain components that suppress possible interference, both emission as well as susceptibility, to the technical requirements for the application of the Regulatory Compliance Mark (RCM). Additionally the electrical circuits conform to the limits prescribed in UNECE Vehicle Regulation No. 10. To avoid false signals or interference, it is standard practice that sensitive instrumentation such as ABS and Tachometers etc. are provided with direct earths.

### Protection against damage due to voltage spikes

This LED lamp is protected against damage from positive voltage spikes caused by events such as load dump conditions up to severity level 3 of ISO 7637-2 and contains a Transient Voltage Suppressor (TVS) designed to withstand a pulse of up to 5000 Watts.

The lamp is protected against reverse polarity connection and negative voltage spikes of up to 1000 volts.

### Electric Welding

Electric Welding may damage the LED lamps. For LED lamps, HELLA recommends the negative connection to be wired isolated from the vehicle chassis. If the lamp uses the chassis as the earth return it is recommended that this earth return is disconnected during electric welding.

## ***FIT AND FORGET - BY DESIGN***

Congratulations, the product you have selected comes from **HELLA** - a world leader in LED lighting design.



Following the launch of the first LED automotive signal lamps in 1990, **HELLA** Design and Innovation continues to set new standards. **HELLA** innovative solutions have been incorporated into millions of lamps, engineered and tested to the most stringent standards, to suit the most demanding environmental conditions.

The cornerstone to the success of our products is our no compromise **Fit and Forget - by Design** philosophy which is incorporated into every step of the product life cycle.

In a world consuming finite resources at an ever faster rate, **Fit and Forget - by Design** is the right environmental choice that also makes perfect economic sense to customers that consider the total life cycle Cost of Ownership.

For general comments about Hella's products please contact us on E-mail at [techfeedback@hella.co.nz](mailto:techfeedback@hella.co.nz)