



Mounting instruction Anbauanweisung

L-DL-FSCT
29.05.2014

HELLA KGaA Hueck & Co.

Type: **2SD 980 602**
Typ: (2SD 980 613)

Page 1 / 3
Seite 1 / 3

Belongs to approval no.: **E24 5883**
Gehört zu Gen.-Nr.:

Rear Position-, Stop Lamp with Rear Direction Indicator for Automobile.
Schluss-, Bremsleuchte mit hinterem Fahrtrichtungsanzeiger für Kraftfahrzeuge.

Light source(s): Lichtquelle(n):	Test voltage: Prüfspannung:	Nominal voltage: Nennspannung:	Nominal power: Nennleistung:	
1 Rear Position Lamp Schlussleuchte	6 LEDs	13.5V or / oder 28V	12V or / oder 24V	1W
1 Stop Lamp Bremsleuchte	18 LEDs	13.5V or / oder 28V	12V or / oder 24V	5W
2 Rear Direction Indicator Hinterer Fahrtrichtungsanzeiger	12 LEDs	13.5V or / oder 28V	12V or / oder 24V	5W

✧ = Centre of reference in accordance with the ECE-Regulations-No.: 3, 6 and 7.
Bezugspunkt nach den ECE-Regelungen-Nr.: 3, 6 und 7.

✧ = Centre of reference for the definition for illuminating surface in accordance with the Council Directive 76/756 EEC or ECE-Regulation No. 48 (see Annex A).
Bezugspunkt zur Bestimmung der Grenzen der leuchtenden Fläche nach 76/756 EWG bzw. ECE-Regelung Nr. 48. Markierung s. auf der Abschluss-Scheibe. Maße s. Anlage A.

Axis of reference: Parallel to the car centre line and parallel to the road.
Bezugsachse: Parallel zur Fahrzeuglängsachse und parallel zur Fahrbahn.

The lamp can be rotated in 90° steps around the reference axis.
Die Leuchte kann in 90° Schritten gedreht um die Bezugsachse angebaut werden.

For left- and right hand mounting.
Für links- und rechtsseitigen Einbau.

INSTRUCTION SHEET for: **2SD 980 613-xxx**



APPLICATION AND MOUNTING INSTRUCTIONS

DuraLED® Combi STOP / REAR POSITION / DIRECTION INDICATOR LAMP Multivolt (Suitable for 12 and 24 volt systems)

Features Include:

- DuraLED® Combi = Fully sealed and submersible
- DuraLED® Combi = Stop, Rear Position and Rear Direction Indicator in a single lamp
- DuraLED® Combi = Vibration and shock resistant
- DuraLED® Combi = Ultra long service life
- DuraLED® Combi = Ultra fast response time
- DuraLED® Combi = Lens made from advanced Grilamid® material with enhanced impact and chemical resistance
- DuraLED® Combi = Reverse polarity protected
- DuraLED® Combi = Low power consumption
- DuraLED® Combi = Enhanced transient spike protection

Lens Marking and Installation Requirements

This Stop / Rear Position / Rear Indicator Lamp, identified by lens marking 5883 and the logo was manufactured to comply with:

ECE Regulation 6 Category 2a for Rear Direction Indicator Lamps
ECE Regulation 7 for Rear Position (Side) / Stop Lamps

- Lamp mounting surface must be vertical to the ground, and at right angles to the longitudinal axis of the vehicle.
 - Lamp must be visible from 45° inboard and 80° outboard, as well as from 15° above and below the horizontal axis.
 - At least two lamps are required.
 - Lamps must not be mounted less than 350 mm and more than 1500 mm above the ground, two additional lamps can be mounted at a vertical distance no less than 600 mm from the mandatory lamps.
 - Lamps must be mounted within 400 mm of the widest point of the vehicle and no closer than 600 mm together.
 - Lamp is approved to be mounted horizontally and vertically.
- Please refer to ECE Regulation 48 for more details.

Note: Lamp does not include a reflex reflector.

Side View

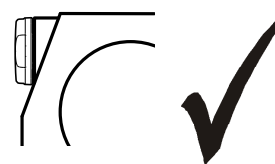
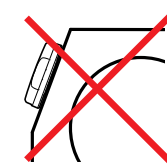

Rear View

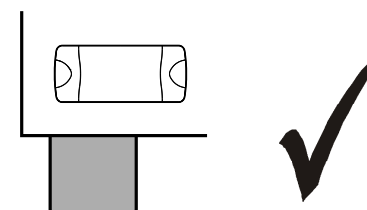
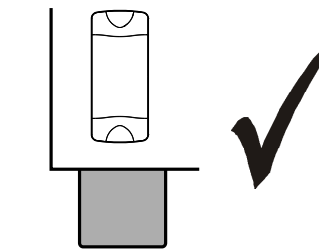

Top View

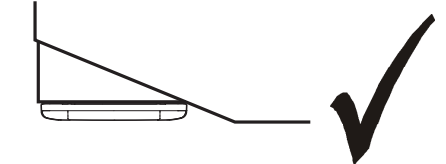
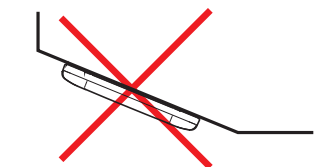



Lamp Mounting Instruction

Screw Cap Removal

Carefully insert a small flat blade screwdriver between the cap and the lens and pull towards the lens, the cap will clip off. To install the cap push in by hand until the top is flush with the lens.

Surface Mounting

- Drill two holes up to 6.5mm Ø at 193mm centres. 6mm Ø screws or bolts are recommended to mount the lamp using the mounting bushes provided.
- Lamp should be mounted on a flat surface.
- If passing the cable through a hole, ensure there are no sharp edges to cut or chafe the cable. Alternatively, cable can be routed through the end of the base.
- Connect lamp as per chart below.
- Try to keep the cable as long as possible, preferably join the cable inside a sealed cable junction box.
- Clip the screw caps on securely until flush with the lamp surface.

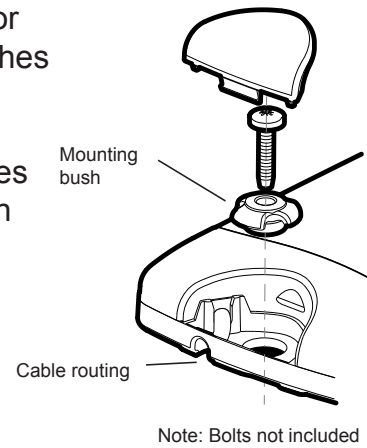

General Dimensions (in millimetres)

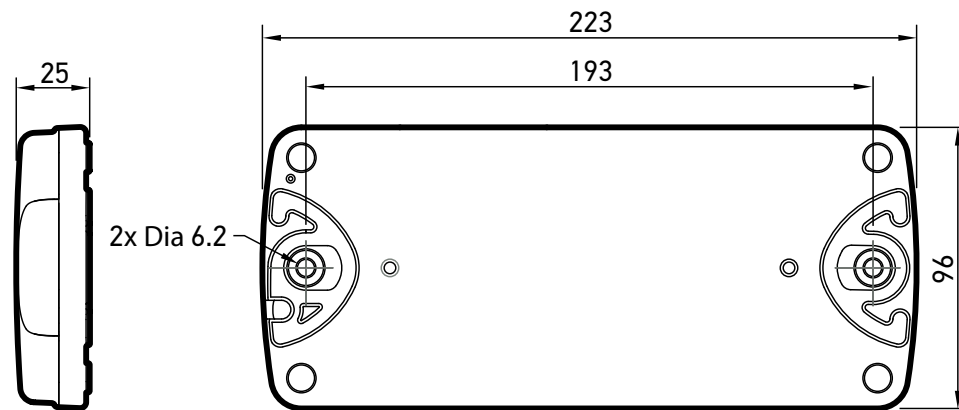

Cable Exit Location

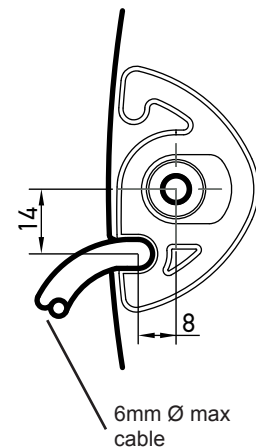

Wiring Colour Coding

Lamp is polarity conscious. The reversal of the polarity will not damage this product but will inhibit its function.

HELLA recommends wire connections be soldered, and heat shrink tubing applied to seal the joint.

Colour	Connect to	Power Consumption
White	Earth (-)	-
Red	Stop (+)	5 watts
Brown	Rear Position (+)	1 watt
Blue	Indicator & HCS Trigger Pulse (+)	5 watts

NB: Lamp must be protected by a fuse rated at 5 amperes maximum.

Direction Indicator Lamps with HCS trigger pulse work in conjunction with HCS / ISO 13207-1 compliant failure detection systems. If additional lamps are fitted beyond the amount supported by the HCS / ISO 13207-1 compliant failure detection system then they must be wired separately so as not to be detected.

Important Notes for Installer and Vehicle Owner



Introduction

Multivolt LED signal and marker lamps offer many advantages over conventional bulb lamps. Significantly reduced power consumption, ultra long life and high tolerance to shock and vibration make LED lamps the ideal choice for the commercial transport industry, where the cost of ownership versus the initial purchase price of the product is well understood.

Compatibility to existing electrical systems

It is important for the installer to ascertain the compatibility of the low power consumption LED lamps with the electrical and/or electronic systems of the complete vehicle, including trailers. In most cases the reduced power consumption is beneficial by imposing less demands on the entire electrical system.

For certain functions some electrical systems rely on a set power consumption for monitoring whether, for example, a trailer is connected.

Operation of this lamp using alternating current or modulated direct voltage will cause premature light failure. HELLA recommends connecting ADR or ECE certified Multivolt LED signal and marker lamps to a continuous (unmodulated) 12V or 24V power supply to ensure safe light operation.

Bulb failure monitoring for indicator lamps

The indicator bulb failure warning (if fitted to the vehicle) relies on the full load of a 21-watt bulb in most cases. LED lamps with trigger pulse have integrated electronics for failure checking, if operating correctly the lamp will pulse a resistive load during the flasher "on" cycle to simulate this load.

If the vehicle manufacturer does not guarantee indicator bulb failure control via the vehicle wiring system than Hella can supply electronic control and flasher units which make it possible to convert the indicator failure system to suit LED lamps with trigger pulse.

Electromagnetic Compatibility (EMC)

This Multivolt LED lamp is an electronic device. The electrical circuits contain components that suppress possible interference, both emission as well as susceptibility, to the limits prescribed in UNECE Vehicle Regulation No. 10. To avoid false signals or interference, it is standard practice that sensitive instrumentation such as ABS and Tachometers etc. are provided with direct earths.

Protection against damage due to voltage spikes

This Multivolt LED lamp is protected against damage from positive voltage spikes caused by events such as load dump conditions specified in ISO 7637 and contains a Transient Voltage Suppressor (TVS) designed to withstand a pulse of up to 5000 Watts.

The lamp is protected against reverse polarity connection and negative voltage spikes of up to 1000 volts.

Electric Welding

Electric Welding may damage the LED lamps. For LED lamps, HELLA recommends the negative connection to be wired isolated from the vehicle chassis. If the lamp uses the chassis as the earth return it is recommended that this earth return is disconnected during electric welding.

FIT AND FORGET - BY DESIGN

Congratulations, the product you have selected comes from **HELLA** - a world leader in LED lighting design.



Following the launch of the first LED automotive signal lamps in 1990, **HELLA** Design and Innovation continues to set new standards. **HELLA** innovative solutions have been incorporated into millions of lamps, engineered and tested to the most stringent standards, to suit the most demanding environmental conditions.

The cornerstone to the success of our products is our no compromise **Fit and Forget - by Design** philosophy which is incorporated into every step of the product life cycle.

In a world consuming finite resources at an ever faster rate, **Fit and Forget - by Design** is the right environmental choice that also makes perfect economic sense to customers that consider the total life cycle Cost of Ownership.

For general comments about Hella's products please contact us on E-mail at techfeedback@hella.co.nz



Mounting instruction
Anbauanweisung

L-DL-FSCT
29.05.2014

HELLA KGaA Hueck & Co.

Type: **2SD 980 602**
Typ: (2SD 980 613)

Page 2 / 3
Seite 2 / 3

Belongs to approval no.: E24 5883
Gehört zu Gen.-Nr.:

Front View
Ansicht von vorn

Side View
Ansicht von der Seite

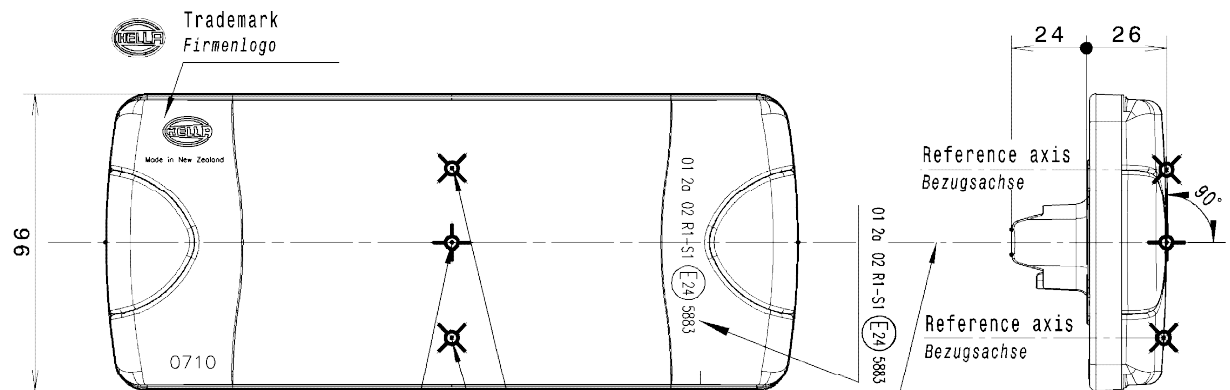

Centre of reference border
of illuminating surface
Bezugspunkt für die Grenzen
der leuchtenden Flächen.

Parallel to road
Parallel zur Fahrbahn

1. Rear position- Stop Lamp
Schluss-Bremsleuchte
2. Rear Direction Indicator
Hinterer Fahrtrichtungsanzeiger

Top View
Ansicht von oben

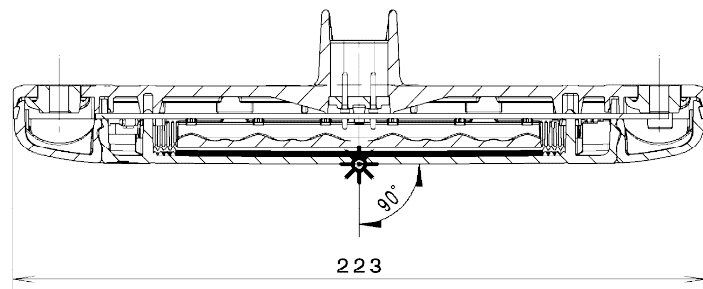

The device must be mounted according to the enclosed fitting documents (e. g. sketch + Annex A).
Der An- bzw. Einbau der Geräte hat nach anliegenden An- bzw. Einbauunterlagen (z. B. Skizze und Anlage A) zu erfolgen.



Mounting instruction
Anbauanweisung

L-DL-FSCT
29.05.2014

HELLA KGaA Hueck & Co.

Type: **2SD 980 602**
Typ: (2SD 980 613)

Page 3 / 3
Seite 3 / 3

Belongs to approval no.: E24 5883
Gehört zu Gen.-Nr.:

Rear View
Ansicht von hinten
2SD 980 602

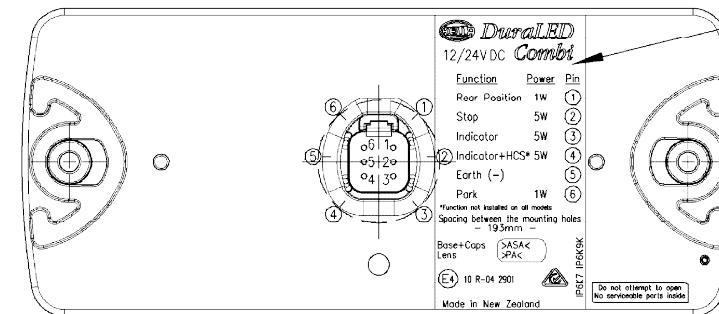

DuraLED
12/24V DC *Combi*

Function	Power	Pin
Rear Position	1W	①
Stop	5W	②
Indicator	5W	③
Indicator+HCS*	5W	④
Earth (-)		⑤
Park	1W	⑥

Rear View
Ansicht von hinten
2SD 980 613

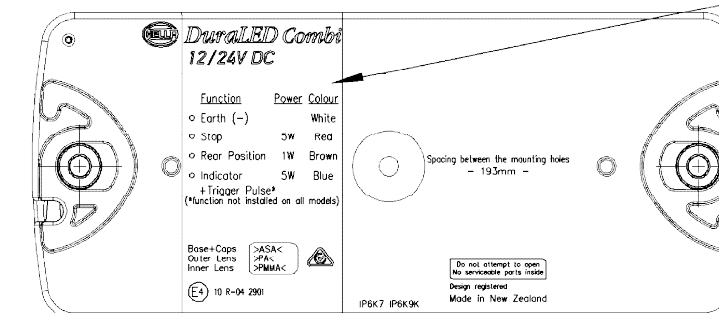

DuraLED Combi
12/24V DC

Function	Power	Colour
Earth (-)		White
Stop	5W	Red
Rear Position	1W	Brown
Indicator	5W	Blue
+Trigger Pulse*		

The device must be mounted according to the enclosed fitting documents (e. g. sketch + Annex A).
Der An- bzw. Einbau der Geräte hat nach anliegenden An- bzw. Einbauunterlagen (z. B. Skizze und Anlage A) zu erfolgen.