



ADR - APPLICATION AND MOUNTING INSTRUCTIONS

**EuroLED® 130mm ROUND STOP/TAIL LAMP
Multivolt 9-33 Volts**

Features

- Single LED design
- Ultra long life
- Reverse polarity protected
- Fully sealed against dust and water
- Low power consumption
- Compensates for voltage drop on long vehicles
- Withstands most vibration and mechanical shock applications
- Manufactured from the latest "high tec" acrylic with enhanced impact and chemical tolerance

Lens Marking and ADR 13/00 Installation Requirements

This Stop/Tail Lamp, identified by lens marking (E4)10208 and the Hella logo was manufactured to comply with ADR 49/00 Rear Position (side) / Stop Lamps

- A tolerance of +/-3 degrees applies on all mounting details.
- Lamp mounting surface must be vertical to the ground, and at right angles to the longitudinal axis of the vehicle.
- Lamp must be visible from 45° inboard and 80° outboard, as well as from 15° above and below the horizontal axis.
- Lamp is approved to be mounted only with lens engraving "TOP" located correctly.
Please refer to ADR 13/00 for more details.

Note: Lamp does not include a reflex reflector

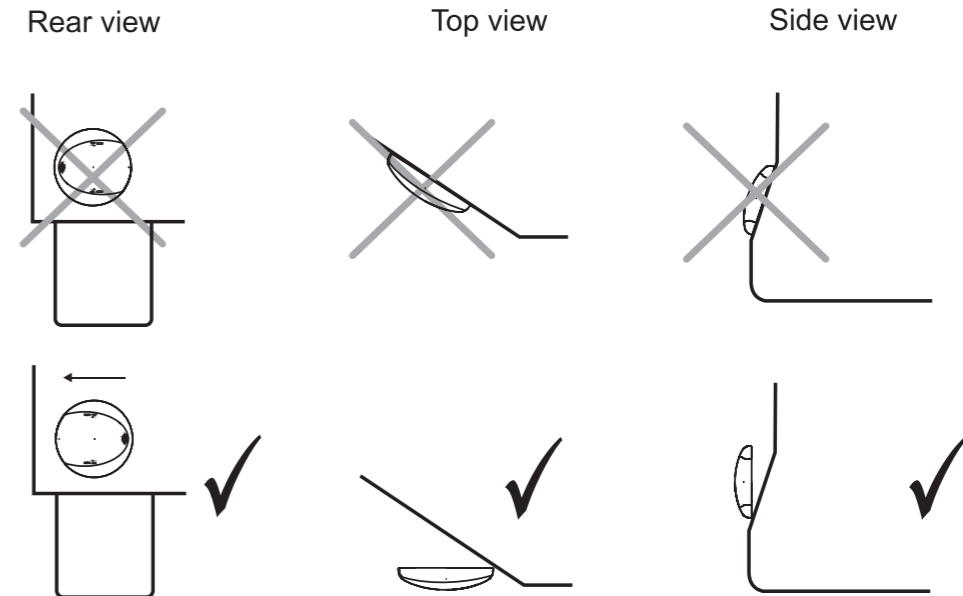

LENS IDENTIFICATION NUMBER: (E4)10208

CATALOGUE NUMBER	ENGINEERING NUMBER	CRN NUMBER	COMPLIANCE NUMBER	ADR 51/00 GLOBE	ADR APPLICABLE
2366	2SB 959 821-00	33196 33198	SL*2366*B RP*2366*B	N/A LED	ADR 49/00
AMENDMENTS				ADR COMPLIANCE VERIFIED <i>X. Blunt</i>	ISSUE DATE: 08/2004
					959 149-70

HELLA-New Zealand Limited, Auckland

INSTRUCTION SHEET
for: **2SB 959 821-00x / 2366 / 2366-BULK**



Lamp Mounting

Do not mount the lamp where damage is likely to be sustained due to tie-downs and other securing devices.

Lamp should be mounted on a flat surface.

Drill two 6mm diameter holes at 110mm centres.

5mm diameter screws or bolts are recommended to mount the lamp using the mounting bushes provided.

Ensure that the engraving "TOP" is located in the correct position.

Note the corresponding arrow under the engraving "TOP" must point to the closest vertical edge of the vehicle.

If passing the cable through a hole, ensure there are no sharp edges to cut or chafe the cable.

Connect the lamp as per the wiring chart shown below.

Try to keep the cable as long as possible, preferably join the cable inside a sealed cable junction box.

Clip the cover on securely until flush with the lamp surface.

Note: when mounting lamp units side by side allow a gap of 5mm to ensure cover removal.

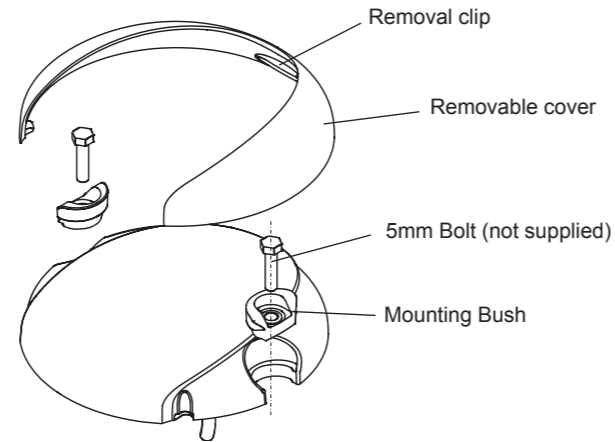

General Dimensions (mm)

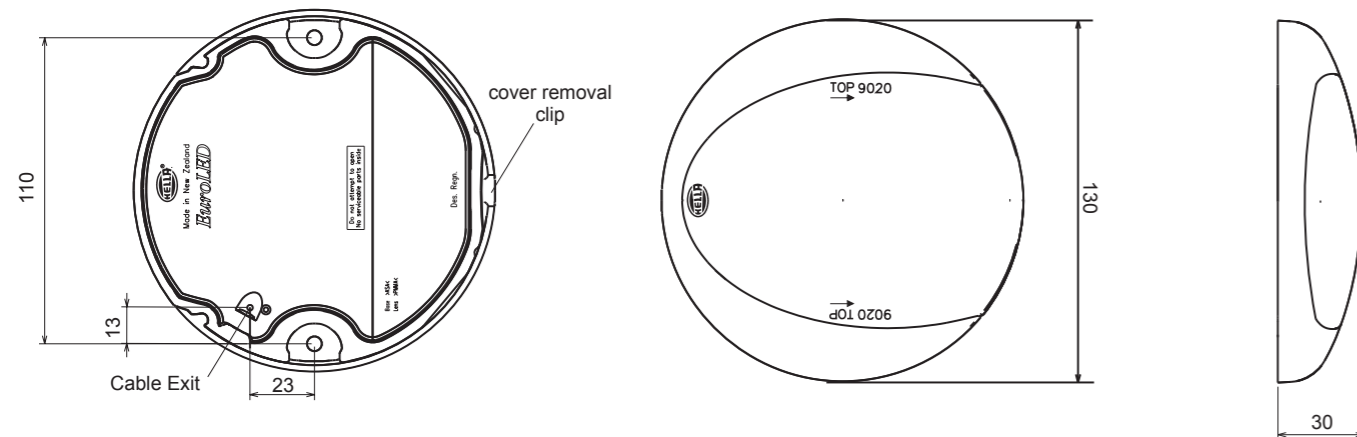

Wiring Colour Coding

LED modules are polarity conscious. Reverse polarity will not damage this product but will inhibit its function. HELLA recommends wire connections be soldered, and heat shrink tubing applied to seal the joint.

Colour	Connect to	Power Consumption
White	Negative (-)	
Brown	Tail (+)	0.5 watts
Red	Stop (+)	2.5 watts

NB: Lamp(s) must be protected by a fuse rated at 5 amperes maximum.

Important Notes for Installer and Vehicle Owner



Introduction

LED signal and marker lamps offer many advantages over conventional bulb lamps. Significantly reduced power consumption, ultra long life and high tolerance to shock and vibration make the LED lamps the ideal choice for the commercial transport industry, where the cost of ownership versus the initial purchase price of the product is well understood.

Compatibility to existing electrical systems

It is important for the installer to ascertain the compatibility of the low power consumption LED lamps with the electrical and/or electronic systems of the complete vehicle, including trailers. In most cases the reduced power consumption is beneficial by imposing less demands on the entire electrical system. For certain functions some electrical systems rely on a set power consumption for monitoring whether, for example, a trailer is connected.

Operation of this lamp using alternating current or modulated direct voltage will cause premature light failure. HELLA recommends connecting ADR or ECE certified Multivolt LED signal and marker lamps to a continuous (unmodulated) 12V or 24V power supply to ensure safe light operation.

Electromagnetic Compatibility (EMC)

This LED lamp is an electronic device. The electrical circuits contain components that suppress possible interference, both emission as well as susceptibility, to the technical requirements for the application of the Regulatory Compliance Mark (RCM).

To avoid false signals or interference, it is standard practice that sensitive instrumentation such as ABS and Tachometers etc. are provided with direct earths.

Protection against damage due to voltage spikes

This lamp is protected against reverse polarity connection and negative voltage spikes of up to 1000 volts.

Electric Welding

Electric Welding may damage the LED lamps. For LED lamps, HELLA recommends the negative connection to be wired isolated from the vehicle chassis. If the lamp uses the chassis as the earth return it is recommended that this earth return is disconnected during electric welding.

Warranty Statement

Congratulations! The product you have selected comes from HELLA - one of the world's leading manufacturers of lighting products. The product comes with a 5 year warranty from end user purchase covering faults in materials, components or workmanship.

In the unlikely event that you should experience a confirmed warranty related problem with your purchase, HELLA will, at its discretion, either repair, replace or refund the purchase price of the product.

Warranty services may be obtained by returning the product within the warranty period to the HELLA Dealer where the product was originally purchased. This warranty is in addition to and does not preclude any other rights or remedies available to the consumer under any local legislation related to the provision of goods or services.

Our goods come with guarantees that cannot be excluded under the Australian Consumer Law. You are entitled to a replacement or refund for a major failure and for compensation for any other reasonably foreseeable loss or damage. You are also entitled to have the goods repaired or replaced if the goods fail to be of acceptable quality and the failure does not amount to a major failure.

This warranty does not cover:

- 1.) Claim/s as a result of normal wear and tear or of any modifications and / or alterations to the product in any shape or form.
- 2.) Claim/s as a result of non-compliance of the assembly, service and operating instructions and/or any unfit or improper use.
- 3.) Any expenses incurred in the process of making the claim.

Note: For lamps sold in Australia, warranty services are provided by Hella Australia Pty Ltd., 4 Hargrave Place, Mentone, Victoria 3194, Australia
Customer Service 1800 061 729 email: custservice@hella.com https://www.hella.com/hella-au/assets/media_global/IAM_Statement_of_Warranty.pdf

For general comments about Hella's products please contact us on E-mail at techfeedback@hella.co.nz