



**ADR - APPLICATION AND MOUNTING INSTRUCTIONS**

ADR 45/01 External Cabin Lamp  
ADR 6/00 Cat. 5 Supplementary Side Direction Indicator Lamp

**DuraLED® CAB MARKER / SUPP. SIDE DIRECTION INDICATOR LAMP (CAT. 5)  
Multivolt (Suitable for 12 and 24 volt systems)**

**Lens Marking and ADR 13/00 Installation Requirements**

This Cab Marker / Supplementary Side Direction Indicator Lamp, identified by lens marking 0990 and the logo was manufactured to comply with ADR 45/01 External Cabin Lamps & ADR 6/00 Cat. 5 Supplementary Side Direction Indicator Lamps.

- A tolerance of +/-3° applies on all mounting details.
- Lamp reference axis must be horizontal.
- External Cabin Lamp:
  - Mounting surface must be vertical to the ground and be square to the vehicle longitudinal axis.
  - Lamp must be visible between  
Horizontal angle: 45° to the left (parallel with vehicle axis) and 45° to the right  
Vertical angle: 5° above and 15° below the horizontal
- Supplementary Side Direction Indicator Lamp:
  - Mounting surface must be vertical to the ground and be parallel to the vehicle longitudinal axis.
  - Lamp must be visible between  
Horizontal angle: From 5° outboard to the rear to 60° outboard to the rear.  
Vertical angle: 15° above and 15° below the horizontal

Note: Please refer to ADR 13/00 for more details.

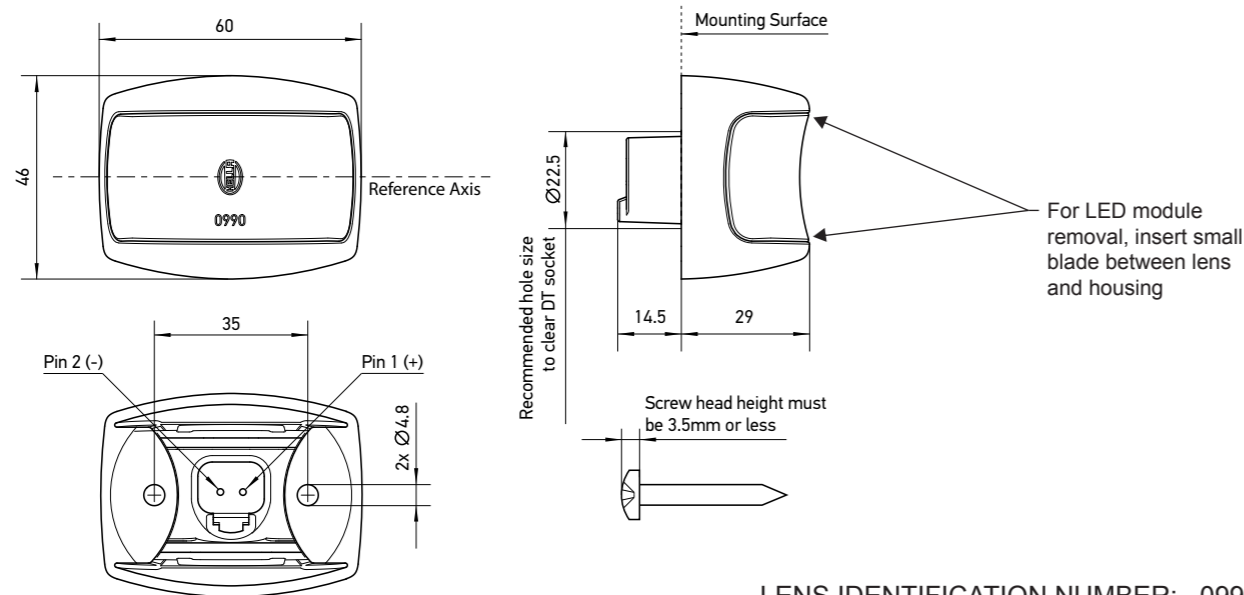

LENS IDENTIFICATION NUMBER: 0990

| CATALOGUE NUMBER | ENGINEERING NUMBER | CRN NUMBER     | COMPLIANCE NUMBER        | ADR 51/00 GLOBE | ADR APPLICABLE         |
|------------------|--------------------|----------------|--------------------------|-----------------|------------------------|
| 2076             | 2BP 980 990-10     | 45810<br>45811 | 2076*ECM°C<br>2076*SDI°C | N/A<br>LED      | ADR 45/01<br>ADR 06/00 |
| AMENDMENTS       |                    |                | ADR COMPLIANCE VERIFIED  | ISSUE DATE:     |                        |
|                  |                    |                |                          | 12/2013         |                        |
|                  |                    |                |                          | 958 780-88      |                        |

HELLA-New Zealand Limited, Auckland



**ADR - APPLICATION AND MOUNTING INSTRUCTIONS**

ADR 45/01 External Cabin Lamp  
ADR 6/00 Cat. 5 Supplementary Side Direction Indicator Lamp

**DuraLED® CAB MARKER / SUPP. SIDE DIRECTION INDICATOR LAMP (CAT. 5)  
Multivolt (Suitable for 12 and 24 volt systems)**

**Lens Marking and ADR 13/00 Installation Requirements**

This Cab Marker / Supplementary Side Direction Indicator Lamp, identified by lens marking 0990 and the logo was manufactured to comply with ADR 45/01 External Cabin Lamps & ADR 6/00 Cat. 5 Supplementary Side Direction Indicator Lamps.

- A tolerance of +/-3° applies on all mounting details.
- Lamp reference axis must be horizontal.
- External Cabin Lamp:
  - Mounting surface must be vertical to the ground and be square to the vehicle longitudinal axis.
  - Lamp must be visible between  
Horizontal angle: 45° to the left (parallel with vehicle axis) and 45° to the right  
Vertical angle: 5° above and 15° below the horizontal
- Supplementary Side Direction Indicator Lamp:
  - Mounting surface must be vertical to the ground and be parallel to the vehicle longitudinal axis.
  - Lamp must be visible between  
Horizontal angle: From 5° outboard to the rear to 60° outboard to the rear.  
Vertical angle: 15° above and 15° below the horizontal

Note: Please refer to ADR 13/00 for more details.

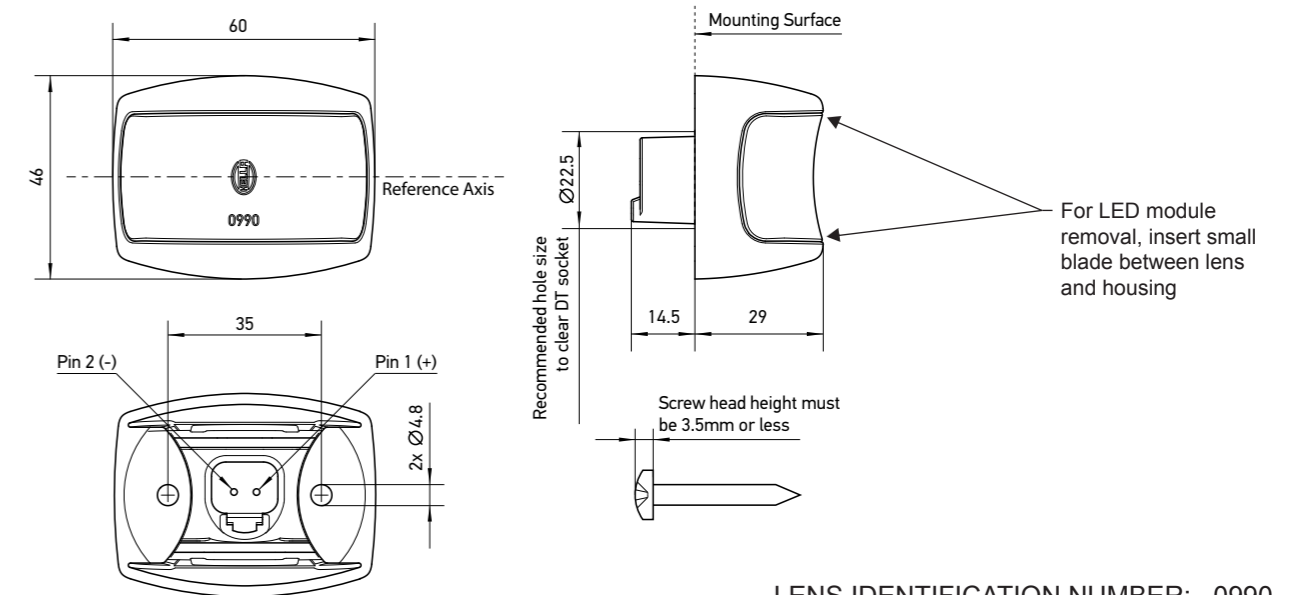

LENS IDENTIFICATION NUMBER: 0990

| CATALOGUE NUMBER | ENGINEERING NUMBER | CRN NUMBER     | COMPLIANCE NUMBER        | ADR 51/00 GLOBE | ADR APPLICABLE         |
|------------------|--------------------|----------------|--------------------------|-----------------|------------------------|
| 2076             | 2BP 980 990-10     | 45810<br>45811 | 2076*ECM°C<br>2076*SDI°C | N/A<br>LED      | ADR 45/01<br>ADR 06/00 |
| AMENDMENTS       |                    |                | ADR COMPLIANCE VERIFIED  | ISSUE DATE:     |                        |
|                  |                    |                |                          | 12/2013         |                        |
|                  |                    |                |                          | 958 780-88      |                        |

HELLA-New Zealand Limited, Auckland



### Lamp Mounting Instructions

- Lamp should be mounted on a flat surface.
- The housing may be used as a template for the mounting holes. Do not mount the lamp where damage is likely to be sustained due to tie-downs and other securing devices.
- Drill two holes up to Ø5 mm at 35mm centres.
- A minimum hole size of Ø22.5 mm is required for the Deutsch 2-way socket in the backplate.
- Mount the housing using Ø4 mm screws or bolts with maximum head height of 3.5mm (not included).
- Prepare the lamp cable (not supplied) using the correct plug connector (Deutsch P/N DT06-2S), wedge (Deutsch P/N W2S) and terminals (Deutsch P/N 0462-201-16141). These Deutsch parts can be purchased separately as a kit (HELLA P/N 4960-P).
- Confirm that the red side of the LED module is facing to the rear of the vehicle by checking the position of the "0990" text against the diagram over page, or by operating the lamp.
- Push the LED module firmly into the housing until it snaps into position.

### LED Module Instructions

The LED module is securely fastened to prevent dislodging in service, and removal would not normally be required. If it becomes necessary to remove the module, insert a small blade on both sides of the LED module and the housing at the correct position and prise the module free from the housing (See diagram over page).

Note: The LED module is fully sealed and has no serviceable components.

### Wiring Colour Coding

The LED lamp is multi voltage capable for optimum brightness in 12 and 24 Volt systems. Lamp is polarity conscious. The reversal of the polarity will not damage this product but will inhibit its function. HELLA recommends wire connections be soldered, and heat shrink tubing applied to seal the joint.

| Pin No. | Connect to   | Power Consumption |
|---------|--------------|-------------------|
| 1       | Positive (+) | < 1W              |
| 2       | Earth (-)    | -                 |

### Energy saving recommendation for 24 volt systems

To derive the full benefit of the low power consumption HELLA recommends to wire pairs of LED side marker lamps in series.

**NB:** Lamp must be protected by a fuse rated at 2 amperes maximum.

### Compatibility to existing electrical systems

It is important for the installer to ascertain the compatibility of the low power consumption LED lamps with the electrical and/or electronic systems of the complete vehicle, including trailers. In most cases the reduced power consumption is beneficial by imposing less demands on the entire electrical system.

For certain functions some electrical systems rely on a set power consumption for monitoring whether, for example, a trailer is connected.

Operation of this lamp using alternating current or modulated direct voltage will cause premature light failure. HELLA recommends connecting ADR or ECE certified Multivolt LED signal and marker lamps to a continuous (unmodulated) 12V or 24V power supply to ensure safe light operation.

## FIT AND FORGET - BY DESIGN

Congratulations, the product you have selected comes from **HELLA** - a world leader in LED lighting design.



Following the launch of the first LED automotive signal lamps in 1990, **HELLA** Design and Innovation continues to set new standards. **HELLA** innovative solutions have been incorporated into millions of lamps, engineered and tested to the most stringent standards, to suit the most demanding environmental conditions.

The cornerstone to the success of our products is our no compromise **Fit and Forget - by Design** philosophy which is incorporated into every step of the product life cycle.

In a world consuming finite resources at an ever faster rate, **Fit and Forget - by Design** is the right environmental choice that also makes perfect economic sense to customers that consider the total life cycle Cost of Ownership.

For general comments about HELLA's products please contact us on E-mail at [techfeedback@hella.co.nz](mailto:techfeedback@hella.co.nz)



### Lamp Mounting Instructions

- Lamp should be mounted on a flat surface.
- The housing may be used as a template for the mounting holes. Do not mount the lamp where damage is likely to be sustained due to tie-downs and other securing devices.
- Drill two holes up to Ø5 mm at 35mm centres.
- A minimum hole size of Ø22.5 mm is required for the Deutsch 2-way socket in the backplate.
- Mount the housing using Ø4 mm screws or bolts with maximum head height of 3.5mm (not included).
- Prepare the lamp cable (not supplied) using the correct plug connector (Deutsch P/N DT06-2S), wedge (Deutsch P/N W2S) and terminals (Deutsch P/N 0462-201-16141). These Deutsch parts can be purchased separately as a kit (HELLA P/N 4960-P).
- Confirm that the red side of the LED module is facing to the rear of the vehicle by checking the position of the "0990" text against the diagram over page, or by operating the lamp.
- Push the LED module firmly into the housing until it snaps into position.

### LED Module Instructions

The LED module is securely fastened to prevent dislodging in service, and removal would not normally be required. If it becomes necessary to remove the module, insert a small blade on both sides of the LED module and the housing at the correct position and prise the module free from the housing (See diagram over page).

Note: The LED module is fully sealed and has no serviceable components.

### Wiring Colour Coding

The LED lamp is multi voltage capable for optimum brightness in 12 and 24 Volt systems. Lamp is polarity conscious. The reversal of the polarity will not damage this product but will inhibit its function. HELLA recommends wire connections be soldered, and heat shrink tubing applied to seal the joint.

| Pin No. | Connect to   | Power Consumption |
|---------|--------------|-------------------|
| 1       | Positive (+) | < 1W              |
| 2       | Earth (-)    | -                 |

### Energy saving recommendation for 24 volt systems

To derive the full benefit of the low power consumption HELLA recommends to wire pairs of LED side marker lamps in series.

**NB:** Lamp must be protected by a fuse rated at 2 amperes maximum.

### Compatibility to existing electrical systems

It is important for the installer to ascertain the compatibility of the low power consumption LED lamps with the electrical and/or electronic systems of the complete vehicle, including trailers. In most cases the reduced power consumption is beneficial by imposing less demands on the entire electrical system.

For certain functions some electrical systems rely on a set power consumption for monitoring whether, for example, a trailer is connected.

Operation of this lamp using alternating current or modulated direct voltage will cause premature light failure. HELLA recommends connecting ADR or ECE certified Multivolt LED signal and marker lamps to a continuous (unmodulated) 12V or 24V power supply to ensure safe light operation.

## FIT AND FORGET - BY DESIGN

Congratulations, the product you have selected comes from **HELLA** - a world leader in LED lighting design.



Following the launch of the first LED automotive signal lamps in 1990, **HELLA** Design and Innovation continues to set new standards. **HELLA** innovative solutions have been incorporated into millions of lamps, engineered and tested to the most stringent standards, to suit the most demanding environmental conditions.

The cornerstone to the success of our products is our no compromise **Fit and Forget - by Design** philosophy which is incorporated into every step of the product life cycle.

In a world consuming finite resources at an ever faster rate, **Fit and Forget - by Design** is the right environmental choice that also makes perfect economic sense to customers that consider the total life cycle Cost of Ownership.

For general comments about HELLA's products please contact us on E-mail at [techfeedback@hella.co.nz](mailto:techfeedback@hella.co.nz)