

## Important Notes for Installer and Vehicle Owner



### Compatibility to existing electrical systems

It is important for the installer to ascertain the compatibility of the low power consumption LED lamps with the electrical and/or electronic systems of the complete vehicle, including trailers. In most cases the reduced power consumption is beneficial by imposing less demands on the entire electrical system.

For certain functions some electrical systems rely on a set power consumption for monitoring whether, for example, a trailer is connected.

Operation of this lamp using alternating current or modulated direct voltage will cause premature light failure. HELLA recommends connecting ADR or ECE certified Multivolt LED signal and marker lamps to a continuous (unmodulated) 12V or 24V power supply to ensure safe light operation.

### Electromagnetic Compatibility (EMC)

This Multivolt LED lamp is an electronic device. The electrical circuits contain components that suppress possible interference, both emission as well as susceptibility, to the technical requirements for the application of the Regulatory Compliance Mark (RCM).

To avoid false signals or interference, it is standard practice that sensitive instrumentation such as ABS and Tachometers etc. are provided with direct earths.

### Protection against damage due to voltage spikes

This Multivolt LED lamp is protected against damage from positive voltage spikes caused by events such as load dump conditions up to severity level 3 of ISO 7637-2 and contains a Transient Voltage Suppressor (TVS) designed to withstand a pulse of up to 5000 Watts.

The lamp is protected against reverse polarity connection and negative voltage spikes of up to 1000 volts.

### Electric Welding

Electric Welding may damage the LED lamps. For LED lamps, HELLA recommends the negative connection to be wired isolated from the vehicle chassis. If the lamp uses the chassis as the earth return it is recommended that this earth return is disconnected during electric welding.

## FIT AND FORGET - BY DESIGN

Congratulations, the product you have selected comes from **HELLA** - a world leader in LED lighting design.



Following the launch of the first LED automotive signal lamps in 1990, **HELLA** Design and Innovation continues to set new standards. **HELLA** innovative solutions have been incorporated into millions of lamps, engineered and tested to the most stringent standards, to suit the most demanding environmental conditions.

The cornerstone to the success of our products is our no compromise **Fit and Forget - by Design** philosophy which is incorporated into every step of the product life cycle.

In a world consuming finite resources at an ever faster rate, **Fit and Forget - by Design** is the right environmental choice that also makes perfect economic sense to customers that consider the total life cycle Cost of Ownership.

For general comments about HELLA's products please contact us on E-mail at [techfeedback@hella.co.nz](mailto:techfeedback@hella.co.nz)

## INSTRUCTION SHEET for: **2BA 959 822-60x / 2133-CS**



### ADR - APPLICATION AND MOUNTING INSTRUCTIONS

## EuroLED® REAR DIRECTION INDICATOR LAMP with HCS TECHNOLOGY Multivolt 9-33 Volts

#### Features

- Single LED design
- Ultra long life
- Reverse polarity protected
- Fully sealed against dust and water
- Low power consumption
- Compensates for voltage drop on long vehicles
- Withstands most vibration and mechanical shock applications
- Manufactured from the latest "high tech" acrylic with enhanced impact and chemical tolerance

#### Lens Marking and ADR 13/00 Installation Requirements

This Rear Direction Indicator Lamp, identified by lens marking 9020 and the **HELLA** logo was manufactured to comply with ADR 6/00 Cat 2a Rear Direction Indicator Lamps.

- A tolerance of +/-3 degrees applies on all mounting details.
- Lamp mounting surface must be vertical to the ground, and at right angles to the longitudinal axis of the vehicle.
- Lamp must be visible from 45° inboard and 80° outboard, as well as from 15° above and below the horizontal axis.
- Lamp is approved to be mounted only with lens engraving "TOP" located correctly. Please refer to ADR 13/00 for more details.

Note: Lamp does not include reflex reflector.

Rear view

Top view

Side view

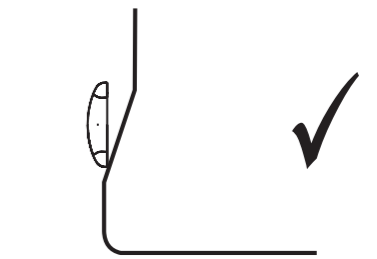
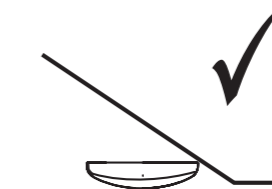
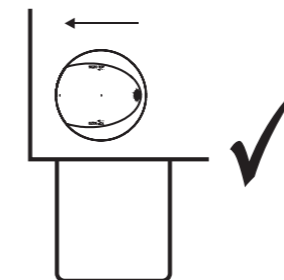
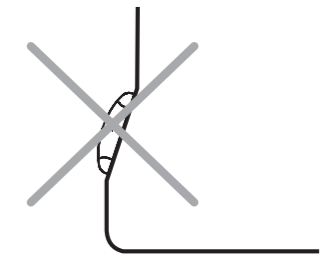
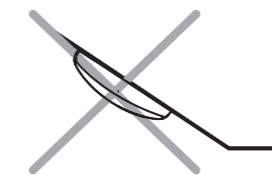
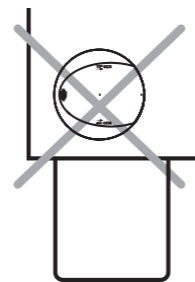

LENS IDENTIFICATION NUMBER: 9020

CATALOGUE NUMBER	ENGINEERING NUMBER	CRN NUMBER	COMPLIANCE NUMBER	ADR 51/00 GLOBE	ADR APPLICABLE
2133-CS	2BA 959 822-60	33191	8 - 2133 - 08	N/A LED	ADR 6/00 Cat 2a
AMENDMENTS				ADR COMPLIANCE VERIFIED	ISSUE DATE:
					02/2008
					959 150-58

HELLA-New Zealand Limited, Auckland

**INSTRUCTION SHEET**  
for: **2BA 959 822-60x / 2133-CS**



**Lamp Mounting Instructions**

Do not mount the lamp where damage is likely to be sustained due to tie-downs and other securing devices.

Lamp should be mounted on a flat surface.

Drill two 6mm diameter holes at 110mm centres.

5mm diameter screws or bolts are recommended to mount the lamp using the mounting bushes provided.

Ensure that the engraving "TOP" is located in the correct position.

Note the corresponding arrow under the engraving "TOP" must point to the closest vertical edge of the vehicle.

If passing the cable through a hole, ensure there are no sharp edges to cut or chafe the cable.

Connect the lamp as per the wiring chart shown below.

Try to keep the cable as long as possible, preferably join the cable inside a sealed cable junction box.

Clip the cover on securely until flush with the lamp surface.

**Note:** When mounting lamp units side by side allow a gap of 5mm to ensure cover removal.

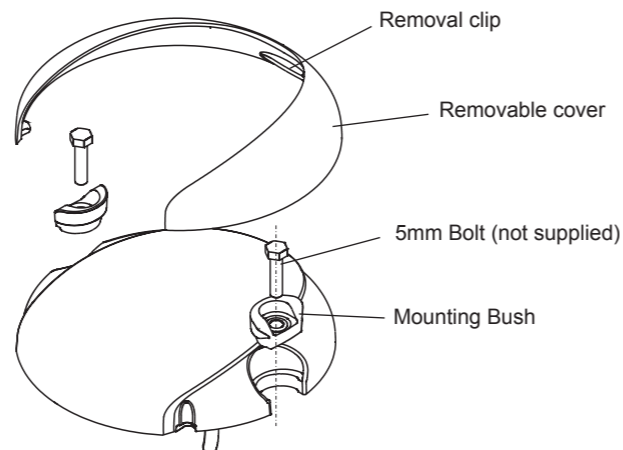

**General Dimensions (in millimetres)**

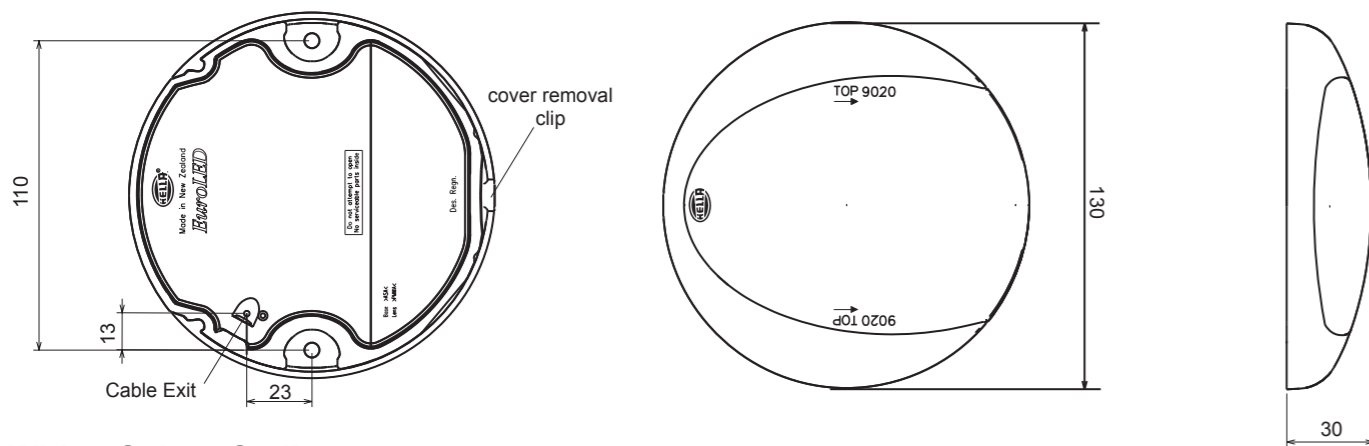

**Wiring Colour Coding**

LED modules are polarity conscious. Reverse polarity will not damage this product but will inhibit its function. HELLA recommends wire connections be soldered, and heat shrink tubing applied to seal the joint.

Colour	Connect to	Power Consumption
White	Earth (-)	-
Yellow	Indicator & HCS trigger pulse (+)	2.5 watts

**NB:** Lamp(s) must be protected by a fuse rated at 5 amperes maximum.

**HCS Direction Indicator Lamps work in conjunction with an HCS failure detection system. If additional lamps are fitted beyond the amount supported by the HCS detection system than they must be wired separately so as not to be detected.**

**Important Notes for Installer and Vehicle Owner**



**Introduction**

Multivolt LED signal and marker lamps offer many advantages over conventional bulb lamps. Significantly reduced power consumption, ultra long life and high tolerance to shock and vibration make the LED lamps the ideal choice for the commercial transport industry, where the cost of ownership versus the initial purchase price of the product is well understood.

**Direction Indicator Lamp Monitoring with the Patented HCS (HELLA Compatibility Solution)**

On vehicles being driven on public roads the operation of the Direction Indicator Lamps must be monitored and a fault must be instantly signalled to the driver. Direction Indicator Lamps are an important road safety feature signalling the direction change intention of the driver. Failure to signal or failure to recognise a direction indicator represents a significant cause for road accidents.

In many countries, LED direction indicator lamps offering a reliable 'Fit and Forget' solution, have become the retrofit item of choice for the cost conscious transport operator. LED lamps, with much lower power consumption and Multivolt features, are often a challenge for existing failure detection control electronics of modern trucks and buses. Transport fleets often feature a mixture of trailer units equipped with either bulb or LED based Direction Indicator Lamps. Each of these trailer units ideally must be freely interchangeable with any of the tractor units in the fleet, including those with 12 volt or 24 volt systems.

Some manufacturers recommend to fit additional resistive loads in parallel to the LED lamps to simulate the 21 watts consumed by a bulb lamp. Such pure resistive load solutions can be problematic for the following reasons:

- a) They mask the possible failure of the actual LED Indicator Lamp itself.
- b) In many cases such pure resistive solutions do not function since they only provide a linear time/current response which is significantly different to the time/current response of a bulb filament when it heats up.
- c) They consume a lot of energy and thus eliminate the desired lower power advantage of an LED lamp.

**Safe conversion to LED Direction Indicator Lamps is now possible with the patented HCS HELLA Compatibility Solution**

HELLA supplies electronic control and flasher units which make it possible to convert the indicator failure system for various vehicles. This is necessary if the vehicle manufacturer does not guarantee indicator bulb failure control via the vehicle wiring system. HCS has been patented by HELLA.

For further information about HCS please refer to the latest HELLA catalogue or the HELLA New Zealand web site, [www.hella.co.nz](http://www.hella.co.nz)