



APPLICATION AND MOUNTING INSTRUCTIONS

DuraLED® AMBER REAR TURN SIGNAL LAMP Multivolt 9 - 33 volts

Features Include:

- DuraLED® = Ultra long service life
- DuraLED® = Ultra fast response time
- DuraLED® = Reverse polarity protected
- DuraLED® = Fully sealed against dust and water
- DuraLED® = Low power consumption
- DuraLED® = Compensates for voltage drop on long vehicles
- DuraLED® = Withstands most vibration and mechanical shock applications
- DuraLED® = Manufactured from polycarbonate to withstand high impact forces

Regulatory Compliance

This lamp identified by lens marking SAE I6 99 DOT and amber colour was manufactured to comply with the applicable test requirements of FMVSS No.108.

Lamp Mounting Instructions and FMVSS No.108 Installation Requirements

- Lamp mounting surface must be vertical to the ground, and at right angles to the longitudinal axis of the vehicle.
- Lamp must be visible from 45° inboard and 80° outboard, as well as from 15° above and below the horizontal axis.
- Lamp is approved to be mounted horizontally or vertically.

Please refer to FMVSS No.108, Table II for more details.

Note: Lamp does not include a reflex reflector.

Mounting options

Vertical mount

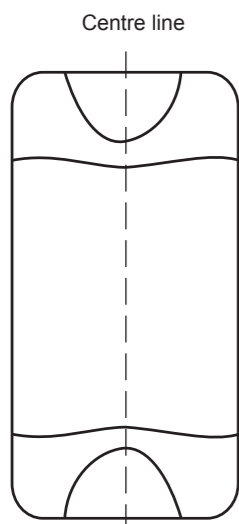

Horizontal mount

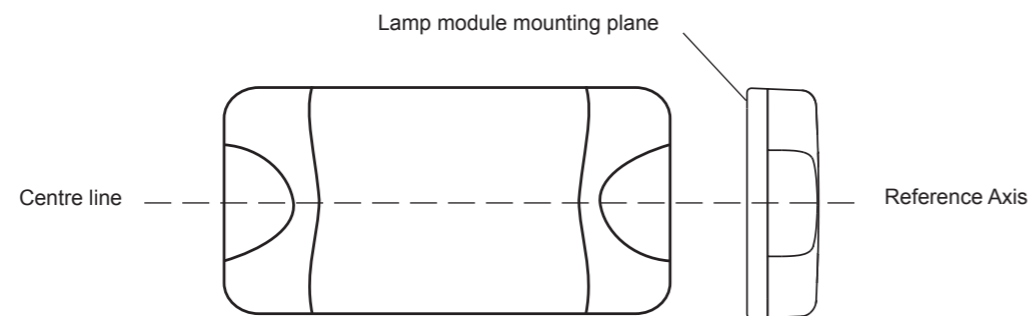

Screw Cap Removal

Carefully insert a small flat blade screwdriver between the cap and lens and pull towards the lens, the cap will clip off. To install the cap push in by hand until the top is flush with the lens.



APPLICATION AND MOUNTING INSTRUCTIONS

DuraLED® AMBER REAR TURN SIGNAL LAMP Multivolt 9 - 33 volts

Features Include:

- DuraLED® = Ultra long service life
- DuraLED® = Ultra fast response time
- DuraLED® = Reverse polarity protected
- DuraLED® = Fully sealed against dust and water
- DuraLED® = Low power consumption
- DuraLED® = Compensates for voltage drop on long vehicles
- DuraLED® = Withstands most vibration and mechanical shock applications
- DuraLED® = Manufactured from polycarbonate to withstand high impact forces

Regulatory Compliance

This lamp identified by lens marking SAE I6 99 DOT and amber colour was manufactured to comply with the applicable test requirements of FMVSS No.108.

Lamp Mounting Instructions and FMVSS No.108 Installation Requirements

- Lamp mounting surface must be vertical to the ground, and at right angles to the longitudinal axis of the vehicle.
- Lamp must be visible from 45° inboard and 80° outboard, as well as from 15° above and below the horizontal axis.
- Lamp is approved to be mounted horizontally or vertically.

Please refer to FMVSS No.108, Table II for more details.

Note: Lamp does not include a reflex reflector.

Mounting options

Vertical mount

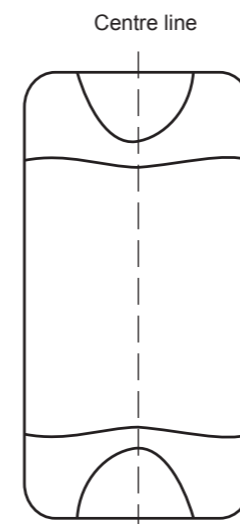

Horizontal mount

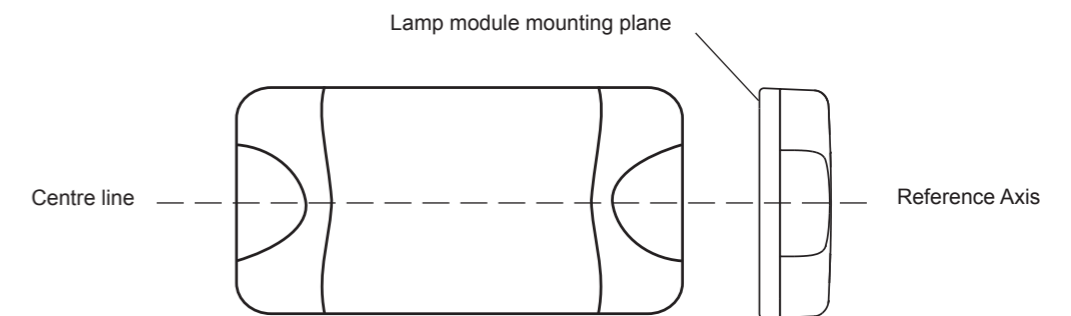

Screw Cap Removal

Carefully insert a small flat blade screwdriver between the cap and lens and pull towards the lens, the cap will clip off. To install the cap push in by hand until the top is flush with the lens.

INSTRUCTION SHEET

for: **2BA 959 070-30x / 2BA 959 070-321**



Surface Mounting

- Drill two holes up to 6.5mm Ø at 148mm centres.
- 6mm Ø screws or bolts are recommended to mount the lamp using the mounting bushes provided.
- Lamp should be mounted on a flat surface.
- If passing the cable through a hole, ensure there are no sharp edges to cut or chafe the cable.
- Alternatively, cable can be routed through the end of the base.
- Connect cable as per table below.
- Try to keep the cable length as long as possible, preferably join the cable inside a sealed cable junction box.
- Clip the screw caps on securely until flush with the lamp surface.

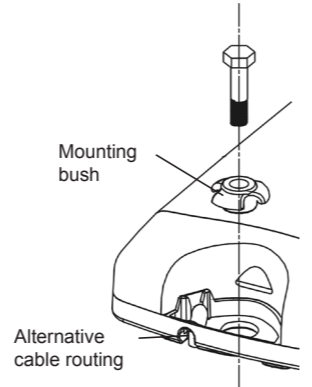

Note: Bolts not included

Note: When mounting lamp units side by side allow a gap of 5mm to ensure screw cap removal.

General Dimensions (in millimetres)

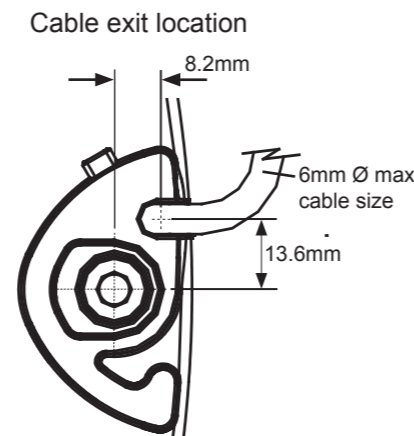
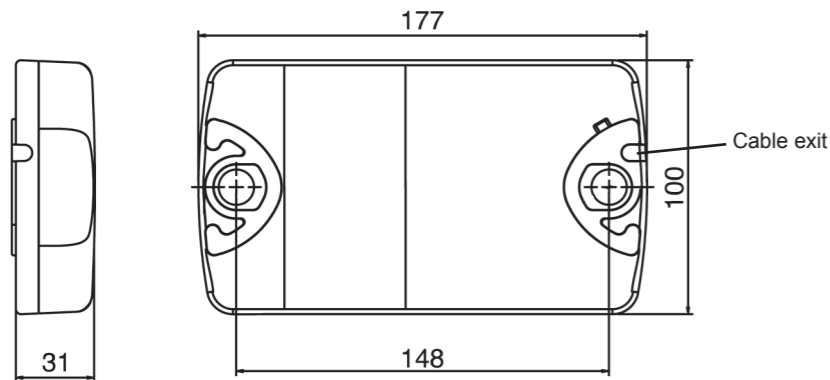

Wiring Colour Coding

Note: Lamp is polarity conscious. The reversal of the polarity will not damage this product but will inhibit its function.

Colour	Connect to	Power Consumption
White	Earth (-)	-
Yellow	Rear Turn Signal (+)	6 watts

Note: Lamp must be protected by a fuse rated at 5 amperes maximum.

Compatibility to existing electrical systems

It is important for the installer to ascertain the compatibility of the low power consumption LED lamps with the electrical and/or electronic systems of the complete vehicle, including trailers. In most cases the reduced power consumption is beneficial by imposing less demands on the entire electrical system. For certain functions some electrical systems rely on a set power consumption for monitoring whether, for example, a trailer is connected. Operation of this lamp using alternating current or modulated direct voltage will cause premature light failure. HELLA recommends connecting SAE compliant Multivolt LED signal and marker lamps to a continuous (unmodulated) 12V or 24V power supply to ensure safe light operation.

FIT AND FORGET - BY DESIGN

Congratulations, the product you have selected comes from **HELLA** - a world leader in LED lighting design.

Following the launch of the first LED automotive signal lamps in 1990, **HELLA** Design and Innovation continues to set new standards. **HELLA** innovative solutions have been incorporated into millions of lamps, engineered and tested to the most stringent standards, to suit the most demanding environmental conditions.

The cornerstone to the success of our products is our no compromise **Fit and Forget - by Design** philosophy which is incorporated into every step of the product life cycle.

In a world consuming finite resources at an ever faster rate, **Fit and Forget - by Design** is the right environmental choice that also makes perfect economic sense to customers that consider the total life cycle Cost of Ownership.

For general comments about HELLA's products please contact us on E-mail at techfeedback@hella.co.nz



INSTRUCTION SHEET

for: **2BA 959 070-30x / 2BA 959 070-321**



Surface Mounting

- Drill two holes up to 6.5mm Ø at 148mm centres.
- 6mm Ø screws or bolts are recommended to mount the lamp using the mounting bushes provided.
- Lamp should be mounted on a flat surface.
- If passing the cable through a hole, ensure there are no sharp edges to cut or chafe the cable.
- Alternatively, cable can be routed through the end of the base.
- Connect cable as per table below.
- Try to keep the cable length as long as possible, preferably join the cable inside a sealed cable junction box.
- Clip the screw caps on securely until flush with the lamp surface.

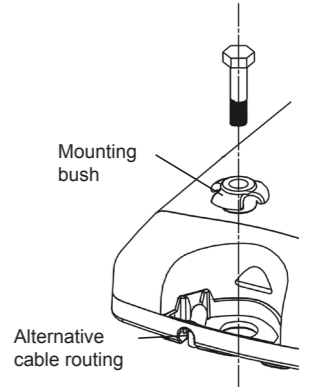

Note: Bolts not included

Note: When mounting lamp units side by side allow a gap of 5mm to ensure screw cap removal.

General Dimensions (in millimetres)

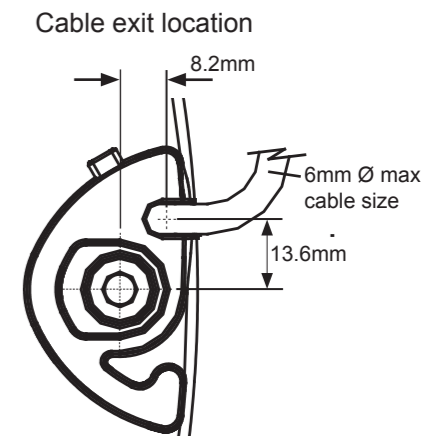
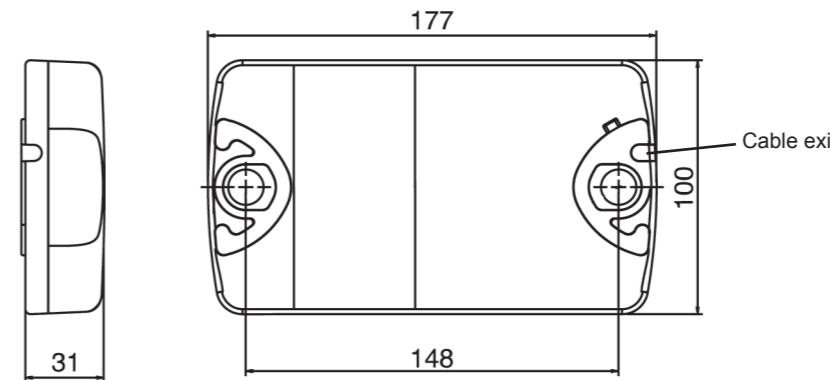

Wiring Colour Coding

Note: Lamp is polarity conscious. The reversal of the polarity will not damage this product but will inhibit its function.

Colour	Connect to	Power Consumption
White	Earth (-)	-
Yellow	Rear Turn Signal (+)	6 watts

Note: Lamp must be protected by a fuse rated at 5 amperes maximum.

Compatibility to existing electrical systems

It is important for the installer to ascertain the compatibility of the low power consumption LED lamps with the electrical and/or electronic systems of the complete vehicle, including trailers. In most cases the reduced power consumption is beneficial by imposing less demands on the entire electrical system. For certain functions some electrical systems rely on a set power consumption for monitoring whether, for example, a trailer is connected. Operation of this lamp using alternating current or modulated direct voltage will cause premature light failure. HELLA recommends connecting SAE compliant Multivolt LED signal and marker lamps to a continuous (unmodulated) 12V or 24V power supply to ensure safe light operation.

FIT AND FORGET - BY DESIGN

Congratulations, the product you have selected comes from **HELLA** - a world leader in LED lighting design.

Following the launch of the first LED automotive signal lamps in 1990, **HELLA** Design and Innovation continues to set new standards. **HELLA** innovative solutions have been incorporated into millions of lamps, engineered and tested to the most stringent standards, to suit the most demanding environmental conditions.

The cornerstone to the success of our products is our no compromise **Fit and Forget - by Design** philosophy which is incorporated into every step of the product life cycle.

In a world consuming finite resources at an ever faster rate, **Fit and Forget - by Design** is the right environmental choice that also makes perfect economic sense to customers that consider the total life cycle Cost of Ownership.

For general comments about HELLA's products please contact us on E-mail at techfeedback@hella.co.nz

