



## APPLICATION AND MOUNTING INSTRUCTIONS

### 110mm ROUND LED REVERSING LAMP Multivolt 9-33V DC

#### Features

- Ultra long life
- Reverse polarity protected
- Fully sealed against dust and water
- Compensates for voltage drop on long vehicles
- Withstands most vibration and mechanical shock applications
- Low power consumption

#### Regulatory Compliance

This Lamp is identified by lens marking SAE R 06 DOT and clear lens colour was manufactured to comply with the applicable test requirements for a two lamp system from FMVSS No. 108.

#### Lamp Mounting Instructions and FMVSS No. 108 Installation Requirements

- Two lamps are required for compliance with FMVSS No. 108.
  - Lamp mounting surface must be vertical to the ground, and at right angles to the longitudinal axis of the vehicle.
  - Lamp must be visible from 45° inboard and outboard, as well as from 10° above and 5° below the horizontal axis.
  - Lamp is approved to be mounted only with lens engraving "TOP" located correctly.
  - Please refer to FMVSS No. 108, Table II from more details.
- Note: Lamp does not include a reflex reflector.

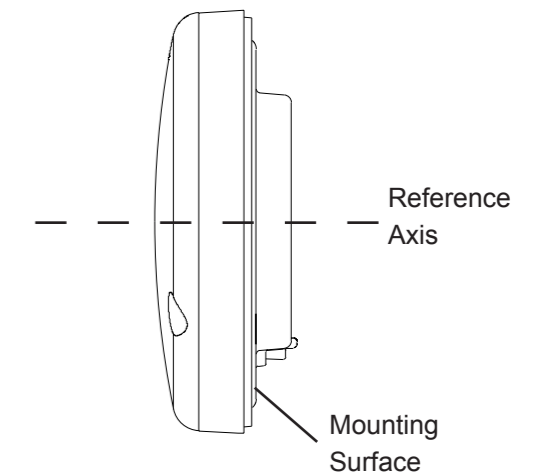
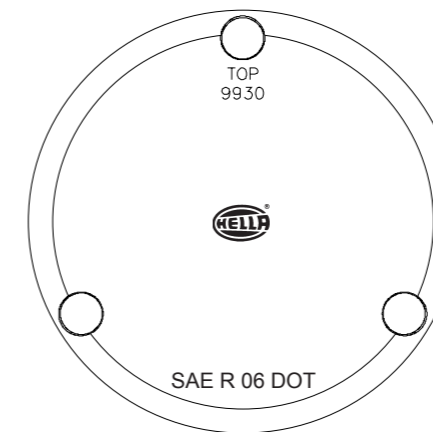

LENS IDENTIFICATION NUMBER: 9930



### Lamp Mounting

#### New Installations

- Lamp should be mounted on a flat surface to avoid mounting stress and as shown in the application and mounting instructions.
- Ensure that the engraving "TOP" is located in the correct position.
- After ascertaining the desired position on the vehicle, cut a hole to fit the lamp as shown in the diagram below. The lamp can then be used as a template to drill the screw/bolt mounting points.
- If passing the cables through a hole, ensure there are no sharp edges to cut or chafe the cable.
- Connect the lamp as per the wiring chart shown below, preferably join the cable inside a sealed cable junction box.
- Push the screws caps on securely until flush with the lamp surface.

General Dimensions (mm)

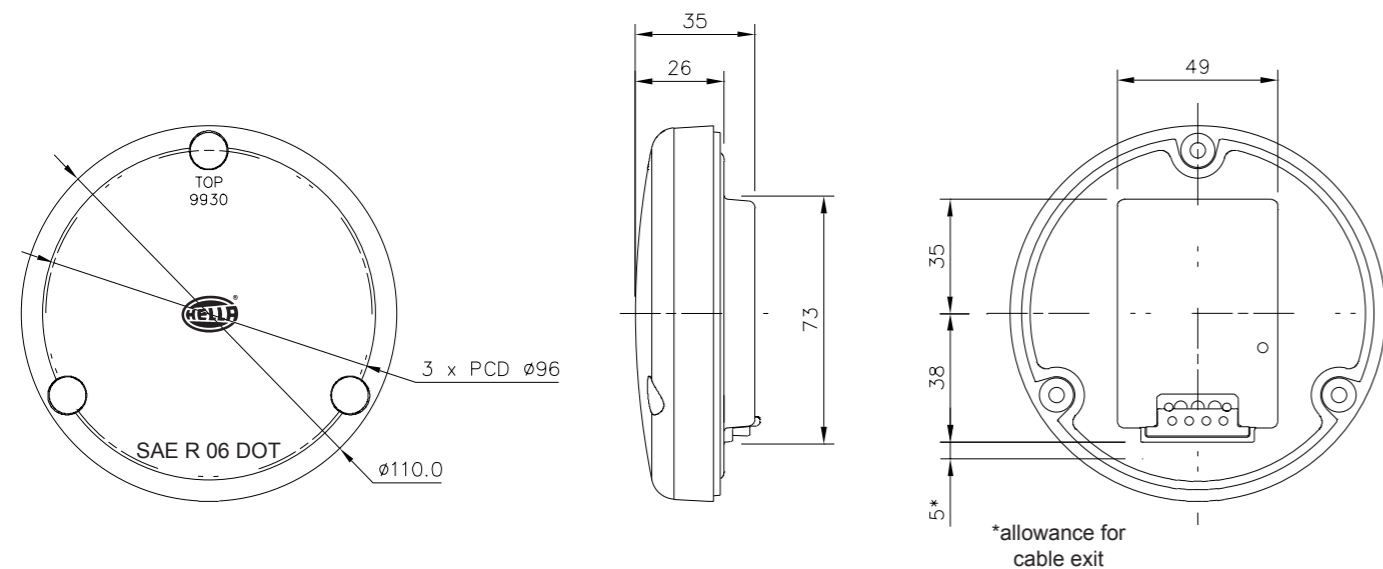

#### Wiring Colour Coding

This lamp is for multivolt capable allowing full light output between 9 and 33 volts DC. LED lamps are polarity conscious. Reverse polarity will not damage this product but will inhibit its function. HELLA recommends wire connections be soldered, and heat shrink tubing applied to seal the joint.

Colour	Connect to	Power Consumption
White	Negative (-)	-
Grey	Reverse (+)	5 watts

**NB:** Lamp must be protected by a fuse rated at 5 amperes maximum.

## Important Notes for Installer and Vehicle Owner



#### Introduction

Multivolt LED signal and marker lamps offer many advantages over conventional bulb lamps. Significantly reduced power consumption, ultra long life and high tolerance to shock and vibration make the LED lamps the ideal choice for the commercial transport industry, where the cost of ownership versus the initial purchase price of the product is well understood.

#### Compatibility to existing electrical systems

It is important for the installer to ascertain the compatibility of the low power consumption LED lamps with the electrical and/or electronic systems of the complete vehicle, including trailers. In most cases the reduced power consumption is beneficial by imposing less demands on the entire electrical system.

For certain functions some electrical systems rely on a set power consumption for monitoring whether, for example, a trailer is connected.

Operation of this lamp using alternating current or modulated direct voltage will cause premature light failure. HELLA recommends connecting SAE compliant Multivolt LED signal and marker lamps to a continuous (unmodulated) 12V or 24V power supply to ensure safe light operation.

#### Electromagnetic Compatibility (EMC)

This LED lamp is an electronic device. The electrical circuits contain components that suppress possible interference, both emission as well as susceptibility, to the limits prescribed in UNECE Vehicle Regulation No. 10.

To avoid false signals or interference, it is standard practice that sensitive instrumentation such as ABS and Tachometers etc. are provided with direct earths.

#### Protection against damage due to voltage spikes

This lamp is protected against reverse polarity connection and negative voltage spikes of up to 1000 volts.

#### Electric Welding

Electric Welding may damage the LED lamps. For LED lamps, HELLA recommends the negative connection to be wired isolated from the vehicle chassis. If the lamp uses the chassis as the earth return it is recommended that this earth return is disconnected during electric welding.

### ***FIT AND FORGET - BY DESIGN***

Congratulations, the product you have selected comes from **HELLA** - a world leader in LED lighting design.



Following the launch of the first LED automotive signal lamps in 1990, **HELLA** Design and Innovation continues to set new standards. **HELLA** innovative solutions have been incorporated into millions of lamps, engineered and tested to the most stringent standards, to suit the most demanding environmental conditions.

The cornerstone to the success of our products is our no compromise **Fit and Forget - by Design** philosophy which is incorporated into every step of the product life cycle.

In a world consuming finite resources at an ever faster rate, **Fit and Forget - by Design** is the right environmental choice that also makes perfect economic sense to customers that consider the total life cycle Cost of Ownership.

For general comments about HELLA's products please contact us on E-mail at [techfeedback@hella.co.nz](mailto:techfeedback@hella.co.nz)