



## ADR - APPLICATION AND MOUNTING INSTRUCTIONS

### ADR 49/00 REAR END OUTLINE LAMP ADR 49/00 REAR POSITION (SIDE) LAMP

This Side Marker Lamp, identified by lens marking 9700 and the  logo was manufactured to comply with ADR 49/00 Rear End-Outline Marker Lamps / Rear Position (Side) Lamp

#### LAMP MAY BE MOUNTED AS FOLLOWS:

- Lamp mounting surface may be vertical to the ground.
- Lamp reference axis must be square to the vehicle longitudinal axis.
- Lamp centre line must be horizontally oriented.

#### ADR 13/00 INSTALLATION REQUIREMENTS

- A tolerance of  $\pm 3^\circ$  applies on all mounting details.
- Geometric visibility:

##### Rear End Outline Lamp

Vertical: From  $5^\circ$  above and  $20^\circ$  below the horizontal

Horizontal: From  $0^\circ$  inwards (parallel with vehicle axis) and  $80^\circ$  outwards

##### Rear Position (Side Lamp)

Vertical: From  $15^\circ$  above and below horizontal

Horizontal: From  $45^\circ$  inwards and  $80^\circ$  outwards

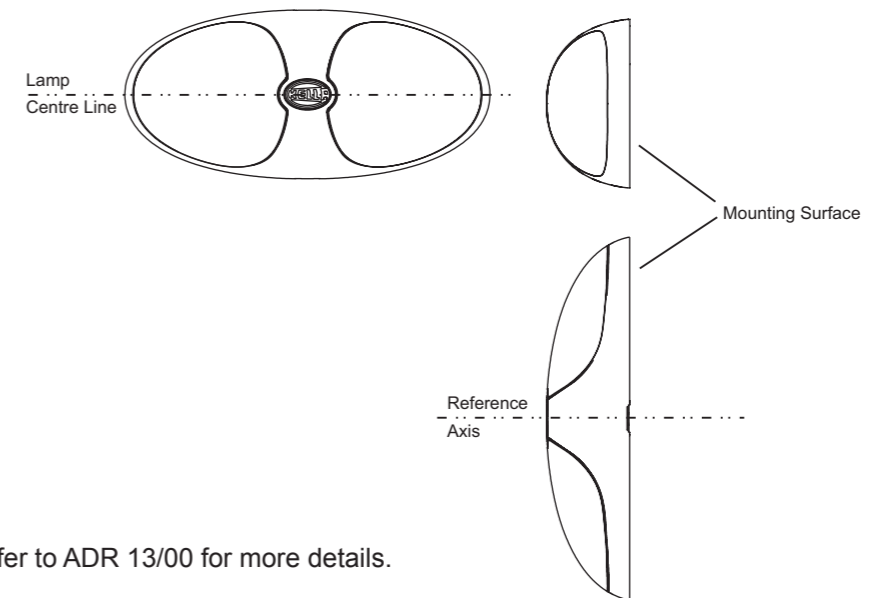

Note: Please refer to ADR 13/00 for more details.

LENS IDENTIFICATION NUMBER: 9700

CATALOGUE NUMBER	ENGINEERING NUMBER	CRN NUMBER	COMPLIANCE NUMBER	ADR 51/00 GLOBE	ADR APPLICABLE
2309	2XA 959 700-30	31431	8-2309-08	N/A LED	ADR 49/00
AMENDMENTS				ADR COMPLIANCE VERIFIED	ISSUE DATE:
02/2009	02/2010				08/2003
					959 149-59

HELLA-New Zealand Limited, Auckland, New Zealand



### Lamp Mounting

Do not mount the lamp where damage is likely to be sustained due to tie-downs and other securing devices.

Lamp should be mounted on a flat surface. Drill two 6mm diameter holes at 47mm centres.

5mm diameter screws or bolts are recommended to mount the lamp using the mounting bushes provided.

If passing the cable through a hole, ensure there are no sharp edges to cut or chafe the cable.

Drill a cable exit hole 6mm diameter in the position as shown on diagram below.

Connect lamp wiring as per chart below.

Try to keep the cable as long as possible, preferably join the cable inside a sealed cable junction box.

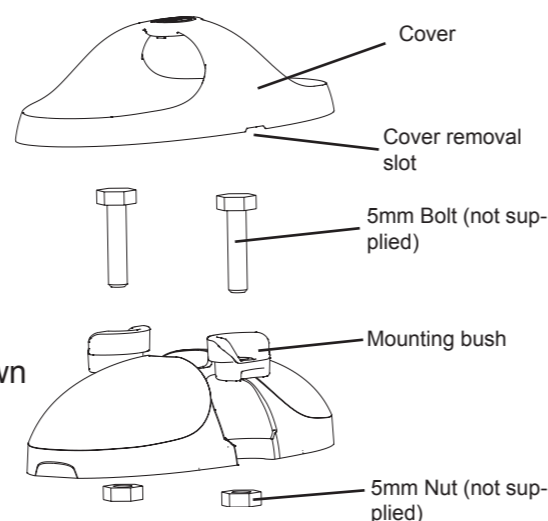

### General Dimensions (mm)

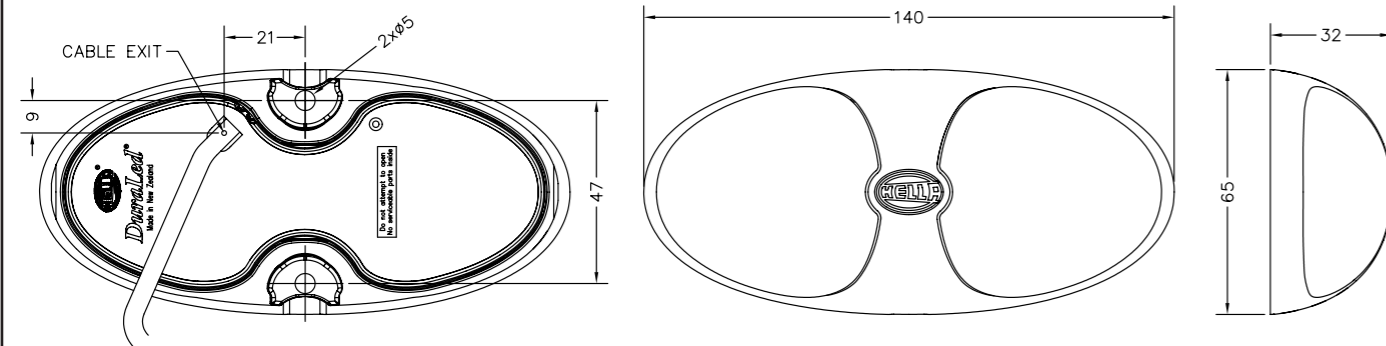

### Wiring Colour Coding

This lamp is Multivolt capable allowing full light output between 9 and 33 volts. LED modules are polarity conscious. Reverse polarity will not damage this product but will inhibit its function. HELLA recommends wire connections be soldered, and heat shrink tubing applied to seal the joint.

Colour	Connect to	Power Consumption
Red	Signal (+)	3W
Black	Negative (-)	-

**NB:** Lamp must be protected by a fuse rated at 5 amperes maximum.

## Important Notes for Installer and Vehicle Owner



### Introduction

Multivolt LED signal and marker lamps offer many advantages over conventional bulb lamps. Significantly reduced power consumption, ultra long life and high tolerance to shock and vibration make the LED lamps the ideal choice for the commercial transport industry, where the cost of ownership versus the initial purchase price of the product is well understood.

### Compatibility to existing electrical systems

It is important for the installer to ascertain the compatibility of the low power consumption LED lamps with the electrical and/or electronic systems of the complete vehicle, including trailers. In most cases the reduced power consumption is beneficial by imposing less demands on the entire electrical system.

For certain functions some electrical systems rely on a set power consumption for monitoring whether, for example, a trailer is connected.

Operation of this lamp using alternating current or modulated direct voltage will cause premature light failure. HELLA recommends connecting ADR or ECE certified Multivolt LED signal and marker lamps to a continuous (unmodulated) 12V or 24V power supply to ensure safe light operation.

### Electromagnetic Compatibility (EMC)

Multivolt LED lamps are electronic devices. The electrical circuits contain components that suppress possible interference, both emission as well as susceptibility, to the technical requirements for the application of the Regulatory Compliance Mark (RCM). Additionally the electrical circuits conform to the limits prescribed in UNECE Vehicle Regulation No. 10.

To avoid false signals or interference, it is standard practice that sensitive instrumentation such as ABS and Tachometers etc. are provided with direct earths.

### Protection against damage due to voltage spikes

This Multivolt LED lamp is protected against damage from positive voltage spikes caused by events such as load dump conditions up to severity level 3 of ISO 7637-2 and contains a Transient Voltage Suppressor (TVS) designed to withstand a pulse of up to 5000 Watts. The lamp is protected against reverse polarity connection and negative voltage spikes of up to 1000 volts.

### Electric Welding

Electric Welding may damage the LED lamps. For LED lamps, HELLA recommends the negative connection to be wired isolated from the vehicle chassis. If the lamp uses the chassis as the earth return it is recommended that this earth return is disconnected during electric welding.

## FIT AND FORGET - BY DESIGN

Congratulations, the product you have selected comes from **HELLA** - a world leader in LED lighting design.



Following the launch of the first LED automotive signal lamps in 1990, **HELLA** Design and Innovation continues to set new standards. **HELLA** innovative solutions have been incorporated into millions of lamps, engineered and tested to the most stringent standards, to suit the most demanding environmental conditions.

The cornerstone to the success of our products is our no compromise **Fit and Forget - by Design** philosophy which is incorporated into every step of the product life cycle.

In a world consuming finite resources at an ever faster rate, **Fit and Forget - by Design** is the right environmental choice that also makes perfect economic sense to customers that consider the total life cycle Cost of Ownership.

For general comments about HELLA's products please contact us on E-mail at [techfeedback@hella.co.nz](mailto:techfeedback@hella.co.nz)