



INSTRUCTION SHEET
for: **2BA 959 822-6xx**

ADR - APPLICATION AND MOUNTING INSTRUCTIONS

**EuroLED 130mm ROUND REAR DIRECTION INDICATOR LAMP
Multivolt 9-33 Volts**

Features

- Single LED design
- Ultra long life
- Reverse polarity protected
- Fully sealed against dust and water
- Failure detection circuitry for use with LED flasher units
- Low power consumption
- Compensates for voltage drop on long vehicles
- Withstands most vibration and mechanical shock applications
- Manufactured from the latest "high tech" acrylic with enhanced impact and chemical tolerance

Lens Marking and Installation Requirements

This Rear Direction Indicator Lamp, identified by lens marking (E4)10208 and the HELLA logo was manufactured to comply with ECE Regulation 6 Category 2a for Rear Direction Indicator Lamps

- A tolerance of +/-3 degrees applies on all mounting details.
- Lamp mounting surface must be vertical to the ground, and at right angles to the longitudinal axis of the vehicle.
- At least two lamps are required.
- Lamps must not be mounted less than 350 mm and more than 1500 mm above the ground, two additional lamps can be mounted up to a height of 2100 mm above the ground.
- Lamps must be mounted within 400 mm from the widest point of the vehicle and no closer than 600 mm together.
- Lamp must be visible from 45° inboard and 80° outboard, as well as from 15° above and below the horizontal axis.
- Lamp is approved to be mounted only with lens engraving "TOP" located correctly.

Note: Lamp does not include a reflex reflector

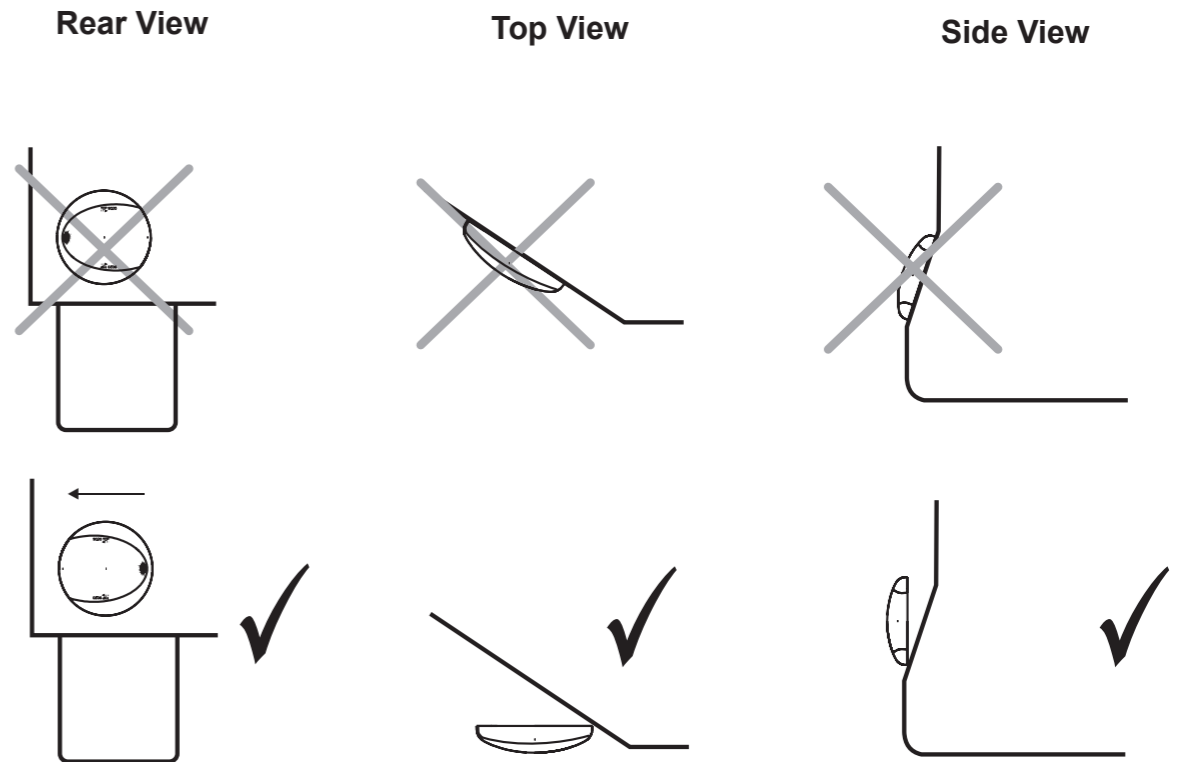

HELLA-New Zealand Limited, Auckland, New Zealand



Hella New Zealand

Typbezeichnung: 2BA 959 822
Euro LED - Single LED

Gehört zur G. Nr.: 10208 E4

Anbauanweisung Nr.:

Rückwärtiger Fahrtrichtungsanzeiger für Kraftfahrzeuge.

Lichtquelle: 1 nicht austauschbare Leuchtdiode

↳ = Bezugspunkt nach den ECE-Regelung 6.

↳ = Bezugspunkt zur Bestimmung der Grenzen der leuchtenden Fläche nach 76/756 EWG bzw. ECE-Regelung Nr. 48. Markierung siehe auf der Abschluss-Schleife. Maße siehe Anlage A.

Bezugsachse: Parallel zur Fahrzeuglängsachse und parallel zur Fahrbahn.

Rechtsanbau dargestellt. Der Linksanbau erfolgt 180° um die Bezugsachse gedreht.

Prüfspannung:
13,5 bzw. 28 Volt

Versorgungsspannung:
9 bis 33 Volt

Nennleistung:
2,5 Watt

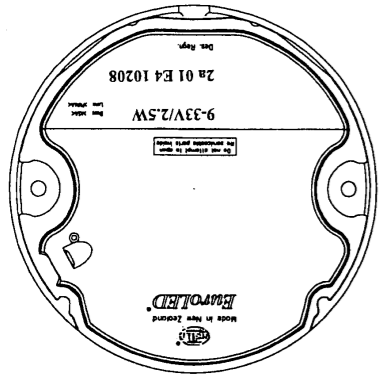
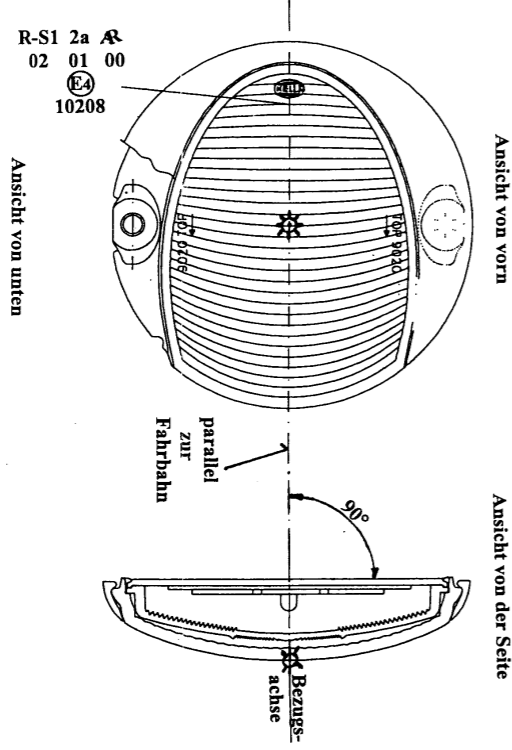

Der Art- bzw. Einbau der Geräte hat nach anliegenden Art- bzw. Einbauunterlagen (z.B. Skizze und Anlage A) zu erfolgen.
2004-06-01



Hella New Zealand

Typbezeichnung: 2BA 959 822

Anlage A

Gehört zur G. Nr.:

Einbauanweisung Nr.:

Bestimmung der Grenzen der leuchtenden Fläche einer Leuchte gemäß den Richtlinien des Rates der Europäischen Gemeinschaften „Anbau von Beleuchtungs- und Lichtsignalanrichtungen“ nach 76/756/EWG bzw. ECE-Regelung Nr. 48, Absatz 2.9.2.

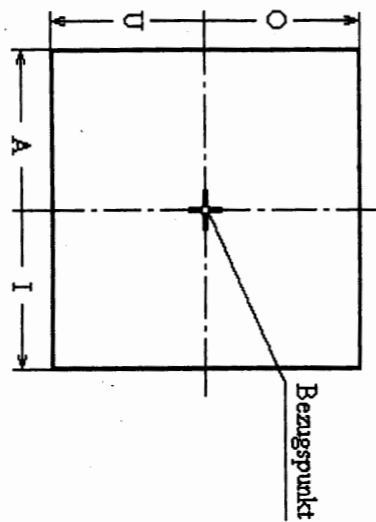

Gerätebezeichnung	Oberer Grenze (O) mm	Untere Grenze (U) mm	Äußere Grenze (A) mm	Innere Grenze (I) mm
Rückwärtiger Fahrtrichtungsanzeiger	28	28	41	38



2004-06-07

INSTRUCTION SHEET
for: **2BA 959 822-6xx**



Lamp Mounting

Do not mount the lamp where damage is likely to be sustained due to tie-downs and other securing devices.

Lamp should be mounted on a flat surface.

Drill two 6mm diameter holes at 110mm centres.

5mm diameter screws or bolts are recommended to mount the lamp using the mounting bushes provided.

Ensure that the engraving "TOP" is located in the correct position.

Note the corresponding arrow under the engraving "TOP" must point to the closest vertical edge of the vehicle.

If passing the cable through a hole, ensure there are no sharp edges to cut or chafe the cable.

Connect the lamp as per the wiring chart shown below.

Try to keep the cable as long as possible, preferably join the cable inside a sealed cable junction box.

Clip the cover on securely until flush with the lamp surface.

Note: When mounting lamp units side by side allow a gap of 5mm to ensure cover removal.

General Dimensions (mm)

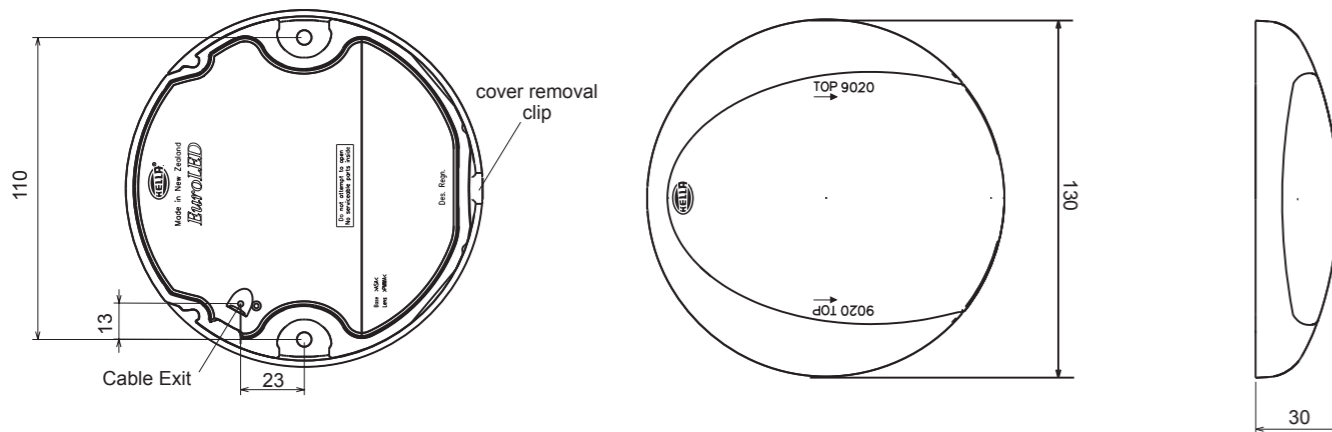

Wiring Colour Coding

LED modules are polarity conscious. Reverse polarity will not damage this product but will inhibit its function. HELLA recommends wire connections be soldered, and heat shrink tubing applied to seal the joint.

Colour	Connect to	Power Consumption
White	Earth (-)	-
Yellow	Indicator & Trigger pulse (+)	2.5 watts

NB: Lamp(s) must be protected by a fuse rated at 5 amperes maximum.

Direction Indicator Lamps with trigger pulse work in conjunction with a failure detection system such as LED flasher units. If additional lamps are fitted beyond the amount supported by the failure detection system than they must be wired separately so as not to be detected.

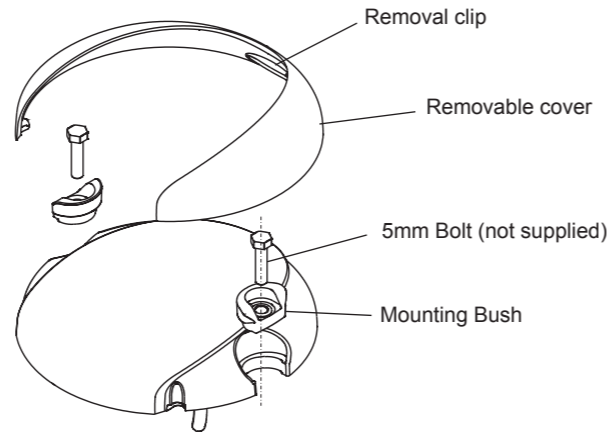

Important Notes for Installer and Vehicle Owner



Introduction

Multivolt LED signal and marker lamps offer many advantages over conventional bulb lamps. Significantly reduced power consumption, ultra long life and high tolerance to shock and vibration make the LED lamps the ideal choice for the commercial transport industry, where the cost of ownership versus the initial purchase price of the product is well understood.

Compatibility to existing electrical systems

It is important for the installer to ascertain the compatibility of the low power consumption LED lamps with the electrical and/or electronic systems of the complete vehicle, including trailers. In most cases the reduced power consumption is beneficial by imposing less demands on the entire electrical system.

For certain functions some electrical systems rely on a set power consumption for monitoring whether, for example, a trailer is connected.

Operation of this lamp using alternating current or modulated direct voltage will cause premature light failure. HELLA recommends connecting ADR or ECE certified Multivolt LED signal and marker lamps to a continuous (unmodulated) 12V or 24V power supply to ensure safe light operation.

Bulb failure monitoring for indicator lamps

The indicator bulb failure warning (if fitted to the vehicle) relies on the full load of a 21-watt bulb in most cases. Multivolt LED lamps with trigger pulse have integrated electronics for failure checking, if operating correctly the lamp will pulse a resistive load during the flasher "on" cycle to simulate this load.

If the vehicle manufacturer does not guarantee indicator bulb failure control via the vehicle wiring system than HELLA can supply electronic control and flasher units which make it possible to convert the indicator failure system to suit Multivolt LED lamps with trigger pulse.

Electromagnetic Compatibility (EMC)

This Multivolt LED lamp is an electronic device. The electrical circuits contain components that suppress possible interference, both emission as well as susceptibility, to the limits prescribed in UNECE Vehicle Regulation No. 10.

To avoid false signals or interference, it is standard practice that sensitive instrumentation such as ABS and Tachometers etc. are provided with direct earths.

Protection against damage due to voltage spikes

This Multivolt LED lamp is protected against damage from positive voltage spikes caused by events such as load dump conditions up to severity level 3 of ISO 7637-2 and contains a Transient Voltage Suppressor (TVS) designed to withstand a pulse of up to 5000 Watts.

The lamp is protected against reverse polarity connection and negative voltage spikes of up to 1000 volts.

Electric Welding

Electric Welding may damage the LED lamps. For LED lamps, HELLA recommends the negative connection to be wired isolated from the vehicle chassis. If the lamp uses the chassis as the earth return it is recommended that this earth return is disconnected during electric welding.

FIT AND FORGET - BY DESIGN

Congratulations, the product you have selected comes from **HELLA** - a world leader in LED lighting design.



Following the launch of the first LED automotive signal lamps in 1990, **HELLA** Design and Innovation continues to set new standards. **HELLA** innovative solutions have been incorporated into millions of lamps, engineered and tested to the most stringent standards, to suit the most demanding environmental conditions.

The cornerstone to the success of our products is our no compromise **Fit and Forget - by Design** philosophy which is incorporated into every step of the product life cycle.

In a world consuming finite resources at an ever faster rate, **Fit and Forget - by Design** is the right environmental choice that also makes perfect economic sense to customers that consider the total life cycle Cost of Ownership.

For general comments about HELLA's products please contact us on E-mail at techfeedback@hella.co.nz