



ADR - APPLICATION AND MOUNTING INSTRUCTIONS

LED SAFETY DAYLIGHTS™ (DRL) KIT - HORIZONTAL MOUNT
5619: 12V DC Only 5619-24V: 24V DC Only

Lens Marking and ADR 13/00 Installation Requirements

This lamp module, identified by lens marking 0880, with clear lens was manufactured to comply with ADR 76/00 Daytime Running Lamp.

- Lamp module mounting surface must be vertical to the ground and facing forward.
- Lamp module reference axis must be parallel to the vehicle longitudinal axis.
- Lamp module centre line must be horizontal.
- Lamp module must be visible from 20° inboard and outboard, as well as from 10° above and below the horizontal axis.
- Two lamp modules are required.
- Lamps modules must not be mounted less than 250 mm and more than 1500 mm above the ground.
- Lamp modules must be mounted within 400 mm of the widest point of the vehicle and no closer than 600 mm together.

Notes: Please refer to ADR 13/00 for more details.

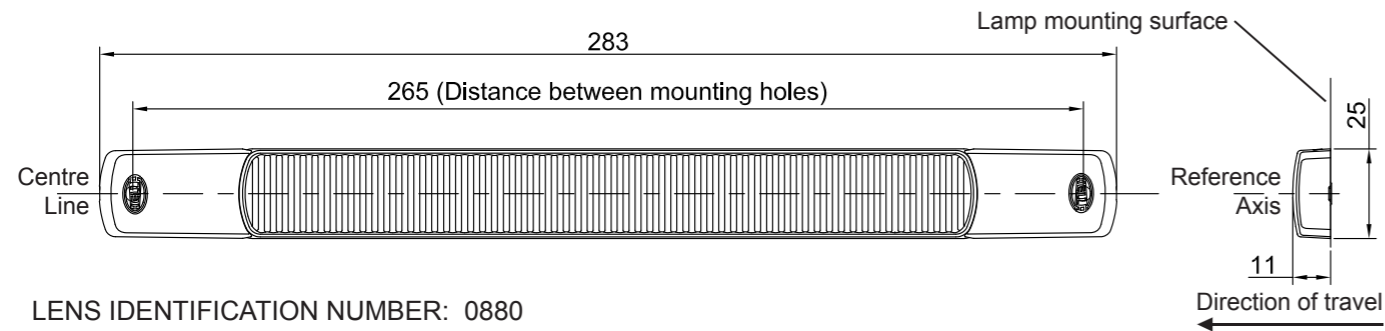

LENS IDENTIFICATION NUMBER: 0880

Product Contents

| Description | 5619 | 5619-24V |
|---------------------------------------|---------------|---------------|
| LED Safety DayLight™ with 2.5 m cable | x2 | x2 |
| Screw Cap | x4 | x4 |
| Mounting Screw | x4 | x4 |
| 5 Pin Change-over Relay | x1 (P/N 3080) | x1 (P/N 3081) |
| Application and Mounting Instructions | x1 | x1 |

| CATALOGUE NUMBER | ENGINEERING NUMBER | CRN NUMBER | COMPLIANCE NUMBER | ADR 51/00 GLOBE | ADR APPLICABLE |
|------------------|----------------------------------|----------------|-----------------------------|-----------------|----------------|
| 1009 1009-24V | 2PT 980 880-00 2PT 980 880-10 | 44200 44202 | NDR12011802 NDR12011801 | N/A LED | ADR 76/00 |
| AMENDMENTS | | | ADR COMPLIANCE VERIFIED | ISSUE DATE: | |
| 04/2012 | 01/2014 | 02/2012 | | | |
| | | | | 958 780-26 | |

Hella-New Zealand Limited, Auckland



ADR - APPLICATION AND MOUNTING INSTRUCTIONS

LED SAFETY DAYLIGHTS™ (DRL) KIT - HORIZONTAL MOUNT
5619: 12V DC Only 5619-24V: 24V DC Only

Lens Marking and ADR 13/00 Installation Requirements

This lamp module, identified by lens marking 0880, with clear lens was manufactured to comply with ADR 76/00 Daytime Running Lamp.

- Lamp module mounting surface must be vertical to the ground and facing forward.
- Lamp module reference axis must be parallel to the vehicle longitudinal axis.
- Lamp module centre line must be horizontal.
- Lamp module must be visible from 20° inboard and outboard, as well as from 10° above and below the horizontal axis.
- Two lamp modules are required.
- Lamps modules must not be mounted less than 250 mm and more than 1500 mm above the ground.
- Lamp modules must be mounted within 400 mm of the widest point of the vehicle and no closer than 600 mm together.

Notes: Please refer to ADR 13/00 for more details.

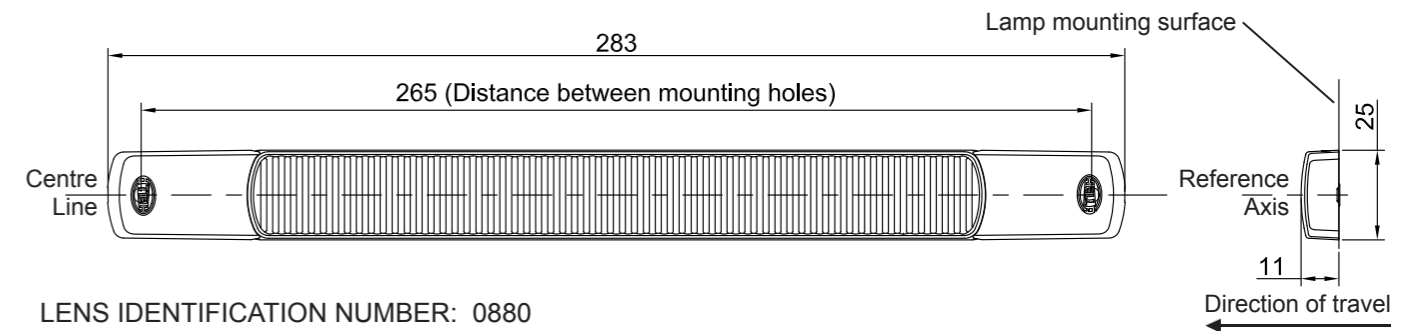

LENS IDENTIFICATION NUMBER: 0880

Product Contents

| Description | 5619 | 5619-24V |
|---------------------------------------|---------------|---------------|
| LED Safety DayLight™ with 2.5 m cable | x2 | x2 |
| Screw Cap | x4 | x4 |
| Mounting Screw | x4 | x4 |
| 5 Pin Change-over Relay | x1 (P/N 3080) | x1 (P/N 3081) |
| Application and Mounting Instructions | x1 | x1 |

| CATALOGUE NUMBER | ENGINEERING NUMBER | CRN NUMBER | COMPLIANCE NUMBER | ADR 51/00 GLOBE | ADR APPLICABLE |
|------------------|----------------------------------|----------------|-----------------------------|-----------------|----------------|
| 1009 1009-24V | 2PT 980 880-00 2PT 980 880-10 | 44200 44202 | NDR12011802 NDR12011801 | N/A LED | ADR 76/00 |
| AMENDMENTS | | | ADR COMPLIANCE VERIFIED | ISSUE DATE: | |
| 04/2012 | 01/2014 | 02/2012 | | | |
| | | | | 958 780-26 | |

Hella-New Zealand Limited, Auckland



Mounting Instructions

- **Lamp must be mounted horizontally on a flat surface with no curvature.**
- Drill two 3 mm Ø mounting holes at 265 mm centres through the mounting surface to allow fitment of the DRL. See previous page for correct positioning.
- Using the mounting screws tighten the DRL to the mounting surface (Maximum torque 1.5Nm).
- Fit screw caps.

Note: Do not overtighten the mounting screws in the plastic lens.
If it is necessary to remove the screw caps, lever them out with a small flat head screw driver.

Wiring Instructions

- It is a legal requirement for daytime running lamps to illuminate only when the ignition is switched ON and the vehicle lighting is switched OFF.
- To meet this requirement it is recommended that a 5 pin change-over relay is utilised as per the wiring diagram below.

| Wire Colour | Connect to | Power Consumption |
|-------------|------------------------------|-------------------|
| Black | Terminal 31: Earth (-) | - |
| Red | Terminal 87a: DRL signal (+) | 3 watts per lamp |

Note 1: Lamps and relay must be protected by a fuse rated at 3 amperes maximum.
Note 2: Lamp is polarity conscious. The reversal of the polarity will not damage this product but will inhibit its function.
Note 3: Daytime running lamps are not a substitute for dipped beam headlights at dusk/dawn or during darkness.

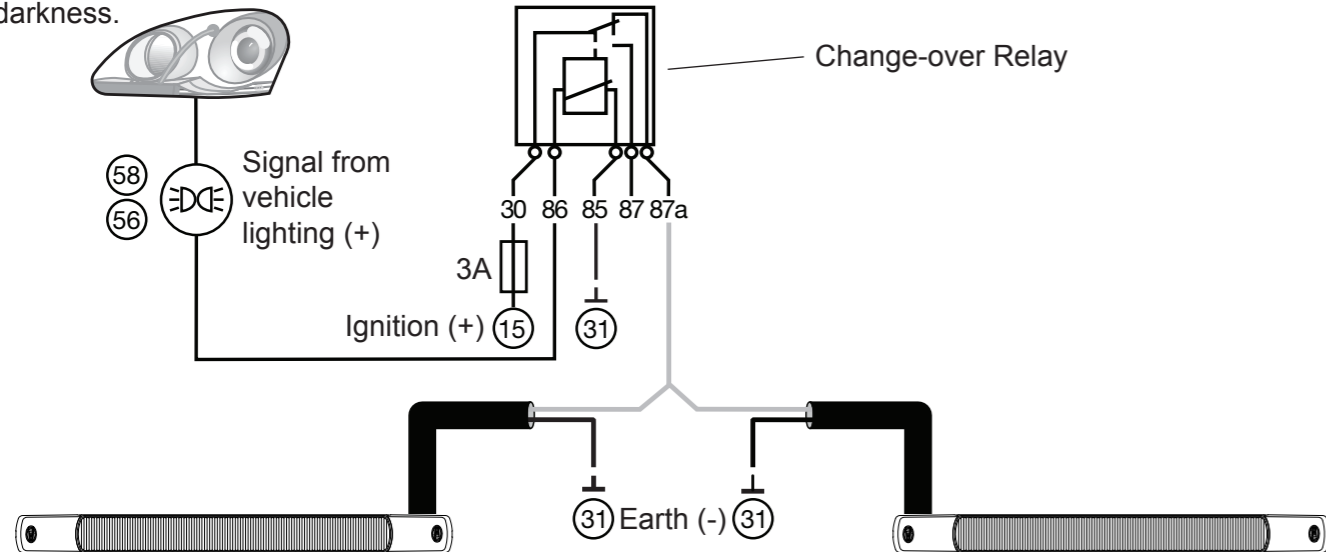

FIT AND FORGET - BY DESIGN

Congratulations, the product you have selected comes from **HELLA** - a world leader in LED lighting design.



Following the launch of the first LED automotive signal lamps in 1990, **HELLA** Design and Innovation continues to set new standards. **HELLA** innovative solutions have been incorporated into millions of lamps, engineered and tested to the most stringent standards, to suit the most demanding environmental conditions.

The cornerstone to the success of our products is our no compromise **Fit and Forget - by Design** philosophy which is incorporated into every step of the product life cycle.

In a world consuming finite resources at an ever faster rate, **Fit and Forget - by Design** is the right environmental choice that also makes perfect economic sense to customers that consider the total life cycle Cost of Ownership.

For general comments about Hella's products please contact us on E-mail at techfeedback@hella.co.nz



Mounting Instructions

- **Lamp must be mounted horizontally on a flat surface with no curvature.**
- Drill two 3 mm Ø mounting holes at 265 mm centres through the mounting surface to allow fitment of the DRL. See previous page for correct positioning.
- Using the mounting screws tighten the DRL to the mounting surface (Maximum torque 1.5Nm).
- Fit screw caps.

Note: Do not overtighten the mounting screws in the plastic lens.
If it is necessary to remove the screw caps, lever them out with a small flat head screw driver.

Wiring Instructions

- It is a legal requirement for daytime running lamps to illuminate only when the ignition is switched ON and the vehicle lighting is switched OFF.
- To meet this requirement it is recommended that a 5 pin change-over relay is utilised as per the wiring diagram below.

| Wire Colour | Connect to | Power Consumption |
|-------------|------------------------------|-------------------|
| Black | Terminal 31: Earth (-) | - |
| Red | Terminal 87a: DRL signal (+) | 3 watts per lamp |

Note 1: Lamps and relay must be protected by a fuse rated at 3 amperes maximum.
Note 2: Lamp is polarity conscious. The reversal of the polarity will not damage this product but will inhibit its function.
Note 3: Daytime running lamps are not a substitute for dipped beam headlights at dusk/dawn or during darkness.

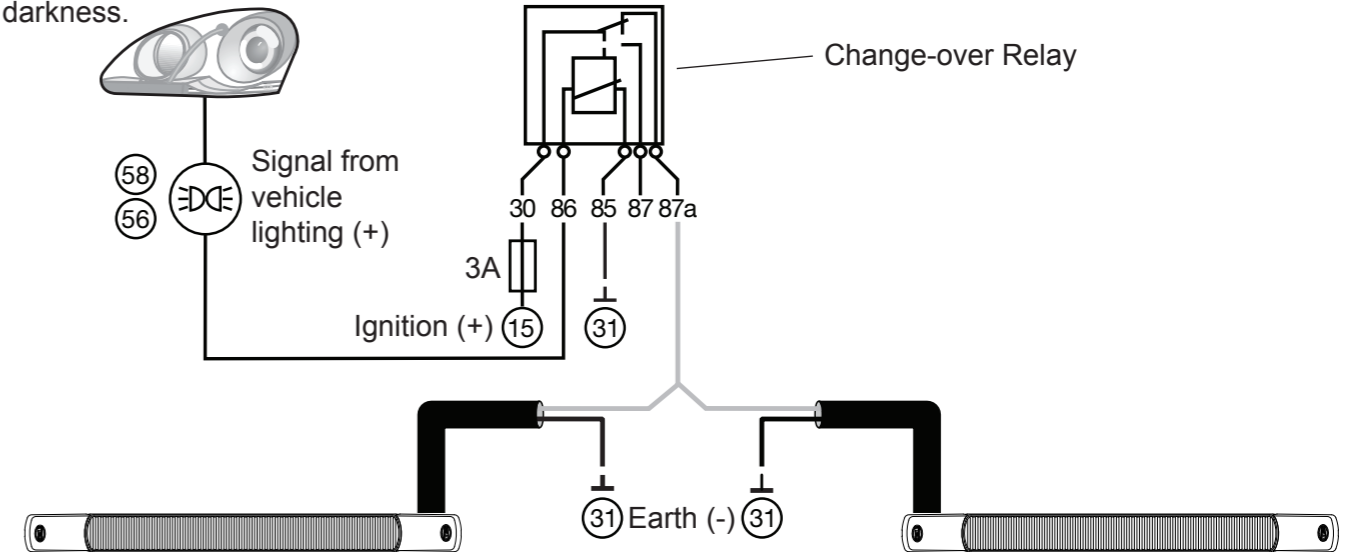

FIT AND FORGET - BY DESIGN

Congratulations, the product you have selected comes from **HELLA** - a world leader in LED lighting design.



Following the launch of the first LED automotive signal lamps in 1990, **HELLA** Design and Innovation continues to set new standards. **HELLA** innovative solutions have been incorporated into millions of lamps, engineered and tested to the most stringent standards, to suit the most demanding environmental conditions.

The cornerstone to the success of our products is our no compromise **Fit and Forget - by Design** philosophy which is incorporated into every step of the product life cycle.

In a world consuming finite resources at an ever faster rate, **Fit and Forget - by Design** is the right environmental choice that also makes perfect economic sense to customers that consider the total life cycle Cost of Ownership.

For general comments about Hella's products please contact us on E-mail at techfeedback@hella.co.nz