

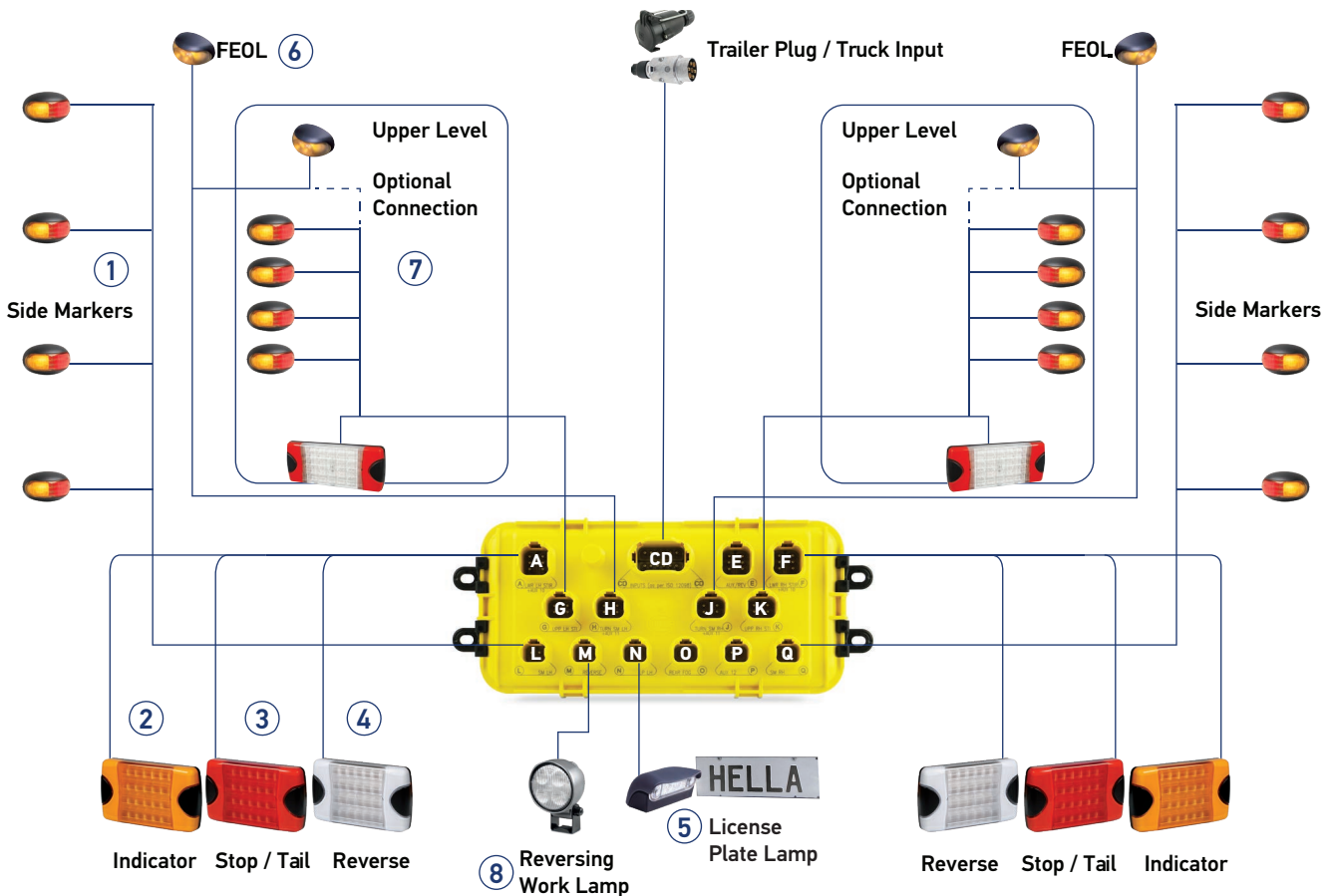

Technology with Vision

PRODUCT SUITABILITY

Designed for low voltage LED lamps, the LED Lamp Distribution Box has circuits that are individually protected to 1.3A each (@ 50° C). This diagram shows a suggested lighting configuration for a commercial trailer with a LED Lamp Distribution Box.



Position	Function	Output Socket	Max Power Consumption		Suggested LED Lamp Part Numbers
			12V	24V	
①	Side Markers	L/Q	15W	30W	30 x 2053 / 2083
②	Rear Indicator	A/F	15W	30W	2 x 2151-H / 2378
③	Stop/Tail	A/F	15W	30W	2 x 2330-H / 2378
④	Reverse	A/F	15W	30W	2 x 1430-H
⑤	License Plate	N	15W	30W	2 x 2559
⑥	Front End Outline	H/J	15W	30W	2 x 2060 / 2051
⑦	Stop/Tail/Indicator	G/K	15W	30W	1 x 2378 + 20 x 2053 / 2083
⑧	Reversing Work Lamp	M	15W	30W	1 x 1551-RE / 1547-RE
TOTAL POSSIBLE FOR SYSTEM			156W or 13A	312W or 13A	