



UP TO
28,000
LUMEN

HYPALUME LED FLOOD LIGHTS



HYPALUME LED FLOOD LIGHTS

Outstanding Light Performance

- Designed for the toughest conditions
- Up to 28,000 lumen
- Choice of 3 different lens options:
Close Range, Long Range and Extra Wide
- DC and AC versions available



TESTED. PROVEN. TRUSTED.

HELLA HypaLUME LED flood lights are tested to International Standards and offer significant advantages over other lighting technologies in heavy duty work environments.

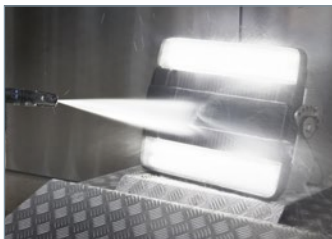

High pressure water
& steam jet cleaning



Temperature overload
down to -40°C



Temperature overload
up to +50°C



Vibration tested

High-Pressure Cleaner Test

For the ultimate in water ingress protection, HELLA products that fulfil the high-pressure cleaner test requirement are able to withstand water and steam jets of up to 80°C and 100 bar that may be encountered during commercial and industrial cleaning processes. This level of protection is provided on HELLA products rated at IPX9K.

Dust Test

Entry of dust can affect the optical and mechanical operation of a lamp, potentially compromising its performance and reliability. HELLA products are designed and tested to ensure the risk of dust ingress is minimised or eliminated. Dust-proof products are rated at IP6KX.

Drop Test and Shock Vibration

The HypaLUME lamp and heavy-duty bracket have been put through vigorous shock vibration testing to ensure the complete lamp will withstand harsh off-road conditions and verifies resistance to potholes, gravel tracks, gravel, stones, fields and dirt roads. This test can also be used to simulate harsh vibration on large mining equipment. The HypaLUME was also put through 10,000 cycles at 200 G to fully test the resistance to impact shock.

Heat, Moisture and Cold Test

In temperature cycle tests, HELLA products are exposed to temperature fluctuations from -40°C to +80°C in climatic chambers. In the "shock chamber", the temperature changes within seconds between -20°C and +80°C. These tests signify utmost stress on any material, both for lighting as well as for the individual electronics components.

Salt-Spray Test

HypaLUME lamps are exposed to 1,500hrs in a salt-spray testing chamber to check corrosion resistance of materials and surface coatings. This accelerated environmental test simulates years of exposure to corrosive salt in order to evaluate the suitability of the materials for use in harsh environments, therefore ensuring the long life of our products.

Vibration Test

This test simulates the exposure of the product to vibration when fitted to large mining equipment. A resonance test is used to determine the mechanical endurance strength of the heavy-duty bracket. Only through 'testing to destruction' methods was the final bracket design approved for heavy duty mining applications.

Superior Material Choices

Engineered reliability

Comprehensive sealing and anti-corrosion measures have been taken to ensure the lamps withstand the toughest conditions. The premium aluminium housing is corrosion resistant with a non-stick and easy to clean surface coating.

Proven durable materials

Heavy duty Grilamid lens* offers unbeatable toughness against impacts and vibration while providing long term UV stability and resistance to commonly used chemicals for the life of the product. *Amber versions use high strength polycarbonate as the lens material.

Reliable in extreme conditions

The HypaLUME is designed to operate over an extreme temperature range from -40°C to $+50^{\circ}\text{C}$. The advanced thermal management draws heat away from the LEDs to maintain the extended life guarantee offered by HELLA's class leading 5 year warranty.

Secure installation

The ultra-heavy duty 316 stainless steel bracket firmly grips the HypaLUME to withstand harsh vibration and impact while also providing easy vertical angle adjustment of up to 140° .



High impact and chemical resistant Grilamid lens in non-amber versions.



Corrosion resistance and improved protection against impact.

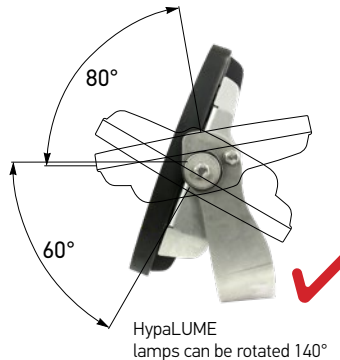

HypaLUME lamps can be rotated 140°



Ultra heavy duty 316 stainless steel bracket allows easy vertical angle adjustment.

Specifically Designed Applications



Mining

Mining is a 24 hour, seven days a week commercial activity. It requires the toughest of all heavy-duty equipment to withstand what is undeniably the harshest of work conditions on the planet. No matter if it is day or night, underground or above ground, the job has to be done. The HypaLUME series of lamps have been created, tested and proven to operate in this most demanding of environments, and to do so day after day, night after night without fear of failure.

Ideal for:

- Mobile equipment
- Fixed installations in working areas



Construction/Light Towers

Work on construction sites is the ultimate test of strength for any material. HELLA lighting systems have passed the most stringent tests in labs and in the field. These tests include resistance to penetration of water and dust, radio noise emission, impact and vibration tests. They are therefore optimally suited for use in the toughest conditions. After surpassing these tests the HypaLUME will feel right at home at any of the world's toughest construction sites.

Ideal for:

- External Site lighting
- Mobile Lighting towers

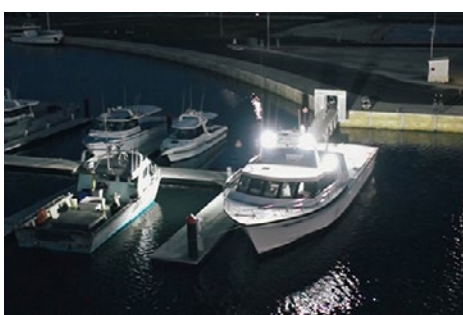

Marine

The HypaLUME series of lamps are ideal for use in marine environments. Used by a wide variety of commercial vessel operators, they illuminate work areas to maximise productivity in activities which run during the darkness hours. The HypaLUME has a high lumen output, completely sealed housing, tolerance to high-pressure water and steam jet cleaning, wide operational voltage range, low radio interference and years of durability in a corrosive salt water environment ensure the heavy-duty lamps can be trusted to perform in challenging and changeable conditions.

Ideal for:

- Large ship decks
- Marina/Berth areas

HypaLUME 110/230V AC LED Flood Light - Heavy Duty

The 110/230V AC HypaLUME has been designed for applications in extreme environments where high output lighting is required. The lamp produces a net output of 28,000 lumens at a voltage input range of 100-240V AC whilst consuming less than 300W.

Comprehensive sealing and anti-corrosion measures have been taken to ensure this lamp withstands the toughest conditions. The premium aluminium housing is corrosion resistant with a non-stick and easy to clean surface coating. Heavy duty Grilamid lens offers unbeatable toughness against impacts and vibration while providing long term UV stability and resistance to commonly used chemicals for the life of the product. The LEDs have a colour temperature of 5700K to provide a near daylight work environment that is optimal for fatigue avoidance and high alertness.

The LED driver electronics ensure light output remains stable over a wide range of voltage variations. The HypaLUME is also protected from reverse polarity and short circuit faults. The HypaLUME is designed to operate over an extreme temperature range from -40°C to +50°C. The advanced thermal management draws heat away from the LEDs to maintain optimum lumen performance for the life of the lamp. This lamp is IP 66 and IP 67 rated for protection against dust, high pressure water jets and temporary water immersion. Also has over voltage, short circuit and over temperature protection.

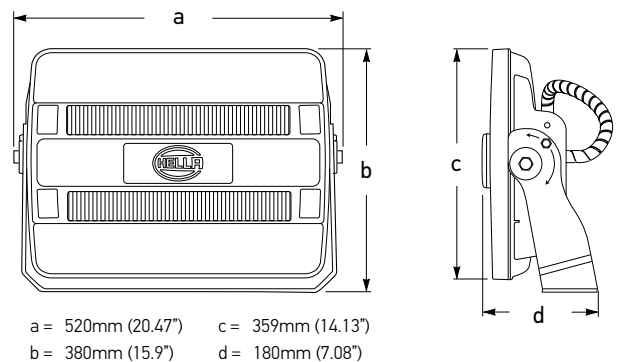

Part Number	1GJ 958 334-031	Extra Wide
	1GJ 958 334-011	Close Range
	1GJ 958 334-021	Long Range

P/N 1GJ 958 334-031

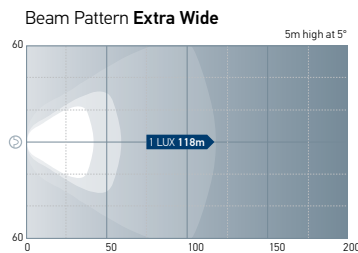

front view

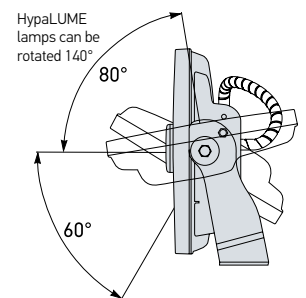

P/N 1GJ 958 334-011

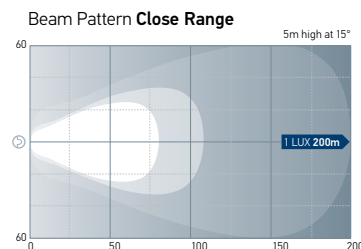

back view



2.0m easy plug-in cable supplied



P/N 1GJ 958 334-021

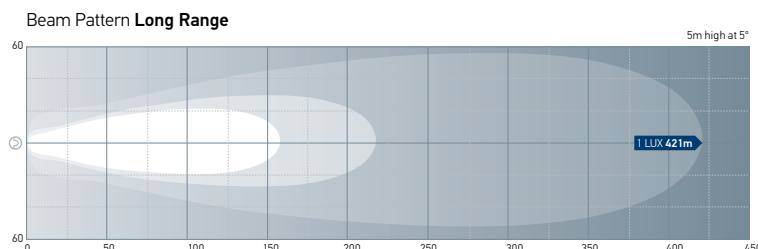



SPECIFICATIONS	
Operating Voltage	100 to 240V AC
Power Consumption	300W max
Actual Light Output	28,000 lumens
Mounting	Upright or pendant
Protection	IP 66 (Protection against dust and high pressure water jets) IP 67 (Protection against dust and temporary water immersion) Over voltage, short circuit and over temperature protection
Operating Temperature	-40°C to +50°C. Reliable in extreme environments.
LED Colour Temperature	5700 K. Optimal for fatigue avoidance and high alertness
Cable Length	Supplied with 2.0m of easy plug-in sheathed cable
Connection	Wieland RST Mini - 16A
Lens Material	High impact and chemical resistant Grilamid lens
Compliance	CE FC 

Actual Light Output



Power Consumption



Operating Voltage



PROTECTION IP 66 IP 67

IP 66 and IP 67
Protection against dust, high pressure water jets and temporary water immersion

APPLICATION

Designed for applications in extreme environments where high output lighting is required.

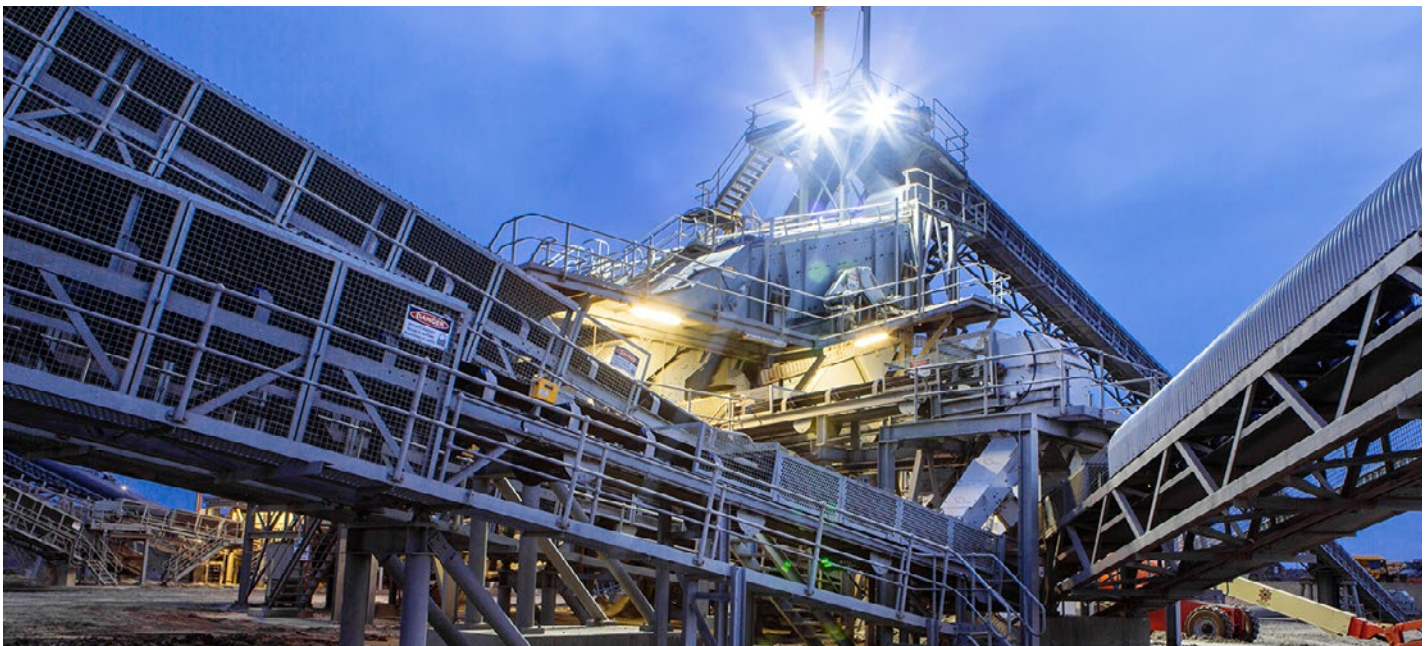
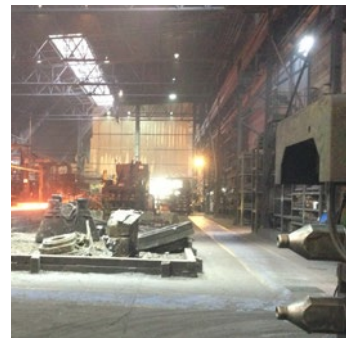
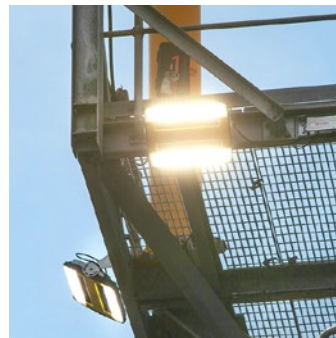

HypaLUME 24/48V DC LED Flood Light - Heavy Duty

The 24/48V DC HypaLUME has been designed for applications in extreme environments where high output lighting is required. The lamp produces a net output of 25,000 lumens at a voltage input range of 22-52V DC whilst consuming less than 260W.

Comprehensive sealing and anti-corrosion measures have been taken to ensure this lamp withstands the toughest conditions. The premium aluminium housing is corrosion resistant with a non-stick and easy to clean surface coating. Heavy duty Grilamid lens offers unbeatable toughness against impacts and vibration while providing long term UV stability and resistance to commonly used chemicals for the life of the product. The LEDs have a colour temperature of 5700K to provide a near daylight work environment that is optimal for fatigue avoidance and high alertness.

The LED driver electronics ensure light output remains stable over a wide range of voltage variations. The HypaLUME is also protected from reverse polarity and short circuit faults. The HypaLUME is designed to operate over an extreme temperature range from -40°C to +50°C. The advanced thermal management draws heat away from the LEDs to maintain optimum lumen performance for the life of the lamp. This lamp is IP 6K9K rated, fully sealed against dust and high-pressure/steam jet cleaning. Also has reverse polarity, transient spike and over voltage protection.



Part Number	1GJ 011 872-521	Extra Wide
	1GJ 011 872-501	Close Range
	1GJ 011 872-511	Long Range

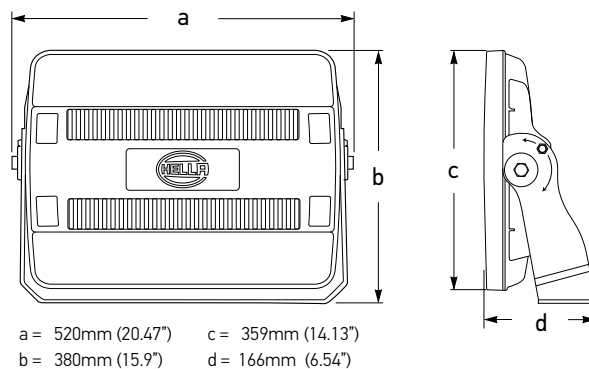

P/N 1GJ 011 872-521

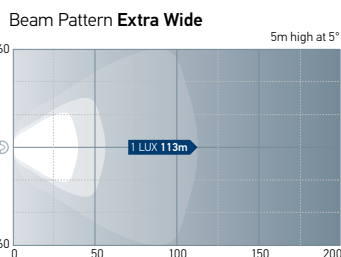

front view



HypaLUME lamps can be rotated 140°

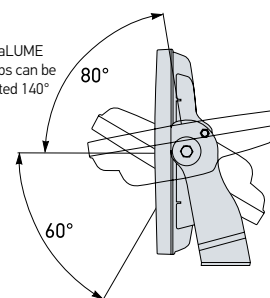

P/N 1GJ 011 872-501

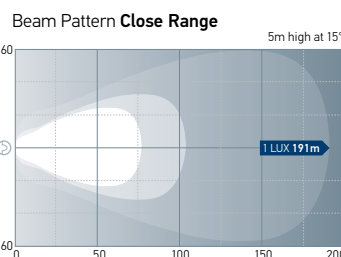

back view



1.8m easy plug-in cable supplied



P/N 1GJ 011 872-511

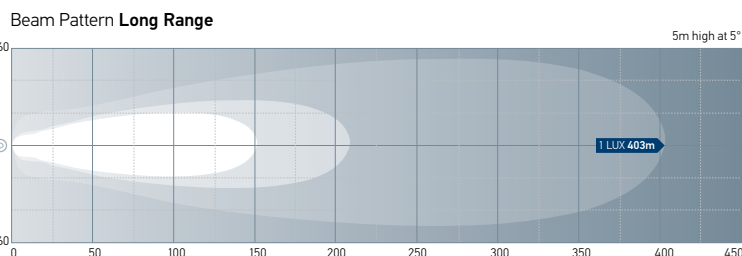



SPECIFICATIONS	
Operating Voltage	22 to 52V DC
Power Consumption	260W max (10A @ 24V DC)
Actual Light Output	25,000 lumens
Mounting	Upright or pendant
Protection	Reverse polarity, transient spike and over voltage protection IP 6K9K (Fully sealed against dust and high-pressure/steam jet cleaning) Advanced thermal management IP 6K7 (Protection against dust and temporary water immersion)
Operating Temperature	-40°C to +50°C. Reliable in extreme environments.
LED Colour Temperature	5700 K. Optimal for fatigue avoidance and high alertness
Cable Length	Supplied with 1.8m of easy plug-in sheathed cable
Connection	4 Pin Deutsch plug
Lens Material	High impact and chemical resistant Grilamid lens
Compliance	CE FC ISO 13766 CISPR25 Class 2 ECE R10

Actual Light Output



Power Consumption



Operating Voltage



IP 6K9K
Fully sealed against dust and high-pressure/steam jet cleaning



Designed for applications in extreme environments where high output lighting is required.

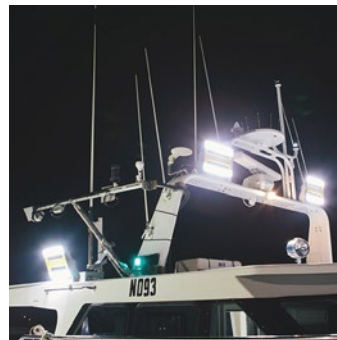
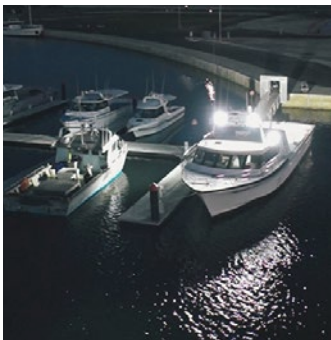

HypaLUME 48V DC RFCommSafe* LED Flood Light - Heavy Duty



The 48V DC RF CommSafe HypaLUME has been designed for applications in extreme environments where high output lighting is required. The lamp produces a net output of 28,000 lumens at a voltage input range of 46-53V DC whilst consuming less than 300W.

Comprehensive sealing and anti-corrosion measures have been taken to ensure this lamp withstands the toughest conditions. The premium aluminium housing is corrosion resistant with a non-stick and easy to clean surface coating. Heavy duty Grilamid lens offers unbeatable toughness against impacts and vibration while providing long term UV stability and resistance to commonly used chemicals for the life of the product. The LEDs have a colour temperature of 5700K to provide a near daylight work environment that is optimal for fatigue avoidance and high alertness.

The LED driver electronics ensure light output remains stable over a wide range of voltage variations. The HypaLUME is also protected from reverse polarity and short circuit faults. The built-in soft start feature eliminates a high in-rush current at start up. The HypaLUME is designed to operate over an extreme temperature range from -40°C to +50°C. The advanced thermal management draws heat away from the LEDs to maintain optimum lumen performance for the life of the lamp. This lamp has IP 6K9K rated protection, it is fully sealed against dust and high-pressure/steam jet cleaning.

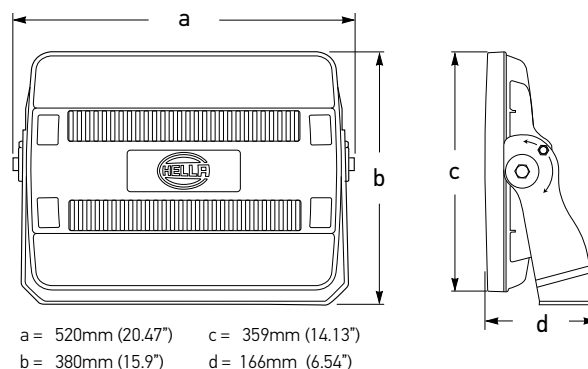

Part Number	1GJ 011 872-241	Extra Wide
	1GJ 011 872-221	Close Range
	1GJ 011 872-231	Long Range

P/N 1GJ 011 872-241

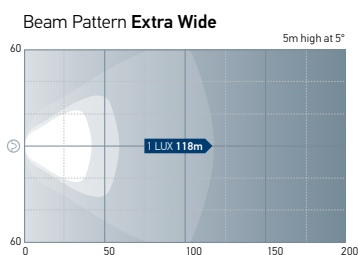

front view

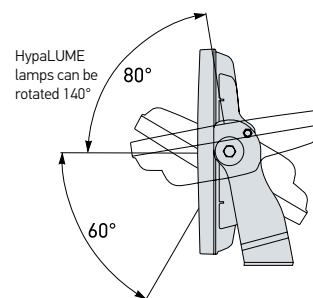

P/N 1GJ 011 872-221

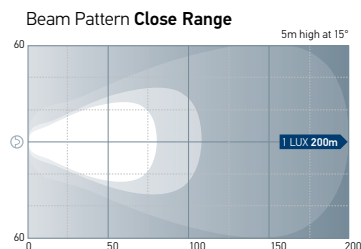

back view



Accessory Cable for DC version P/N 8KB 958 304-001



P/N 1GJ 011 872-231

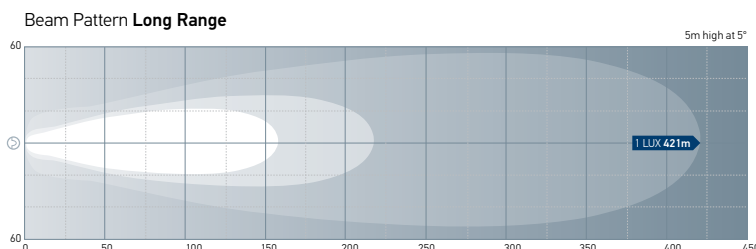

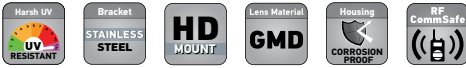

SPECIFICATIONS	
Operating Voltage	46 to 53V DC
Power Consumption	300W max (6.25A @ 48V DC)
Actual Light Output	28,000 lumens
Mounting	Upright or pendant
Protection	Reverse polarity, transient spike and over voltage protection IP 6K9K (Fully sealed against dust and high-pressure/steam jet cleaning) Advanced thermal management IP 6K7 (Protection against dust and temporary water immersion)
Operating Temp.	-40°C to +50°C. Reliable in extreme environments.
LED Colour Temp.	5700 K. Optimal for fatigue avoidance and high alertness
Soft Start	Reduces start-up inrush ramp-up
Connection	4 Pin Deutsch plug
Lens Material	High impact and chemical resistant Grilamid lens
Compliance	CE FC



DC version Accessory Cable sold separately
P/N 8KB 958 304-001

Actual Light Output **Power Consumption** **Operating Voltage**



IP 6K9K
Fully sealed against dust and high-pressure/steam jet cleaning



Designed for applications in extreme environments where high output lighting is required.

***48V DC HypaLUME is designed RfCommSafe**

RfCommSafe products were developed in recognition that some radio communications equipment used by the emergency services and industry will self-tune to higher amplification (high sensitivity) in remote areas. In these situations the limits prescribed in CISPR15 or relevant UNECE Standards might not be sufficient to ensure absolutely no interference. 48V DC HypaLUME is designed to RfCommSafe, ultra low emission (EMC) requirements surpassing International Standards by a wide margin.

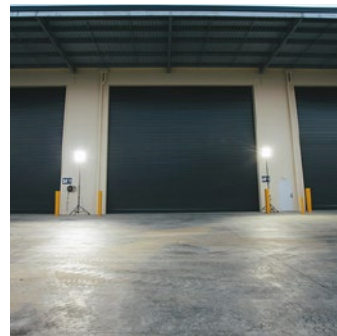

Amber HypaLUME 24/48V DC & 110/230V AC LED Flood Lights

The Amber 24/48V DC & 110/230V AC HypaLUME lamps have been designed for applications in extreme environments where high output lighting is required. Using light with a warmer colour temperature can provide additional improvements in visibility for areas of high Dust, Fog and/or Snowy conditions. These two lamps produce a net output of 19,000 lumens with voltage input ranges of 22-52V DC and 100-240V AC respectively, whilst consuming less than 260W.

Comprehensive sealing and anti-corrosion measures have been taken to ensure this lamp withstands the toughest conditions. The premium aluminium housing is corrosion resistant with a non-stick and easy to clean surface coating. Heavy duty polycarbonate lens offers unbeatable toughness against impacts and vibration. The LEDs have a colour temperature of 2500K to produce significantly reduced glare compared to traditional white flood lighting.

The LED driver electronics ensure light output remains stable over a wide range of voltage variations. The HypaLUME is also protected from over voltage and short circuit faults. The HypaLUME is designed to operate over a temperature range from -40°C to +50°C.



Amber HypaLUME 24/48V DC
1GJ 011 872-601 Close Range



Actual Light Output



(Extra wide: 15,500 lumen typical)



IP 67
Protection against dust, high pressure water jets and temporary water immersion



Designed for applications in environments with high:

- Dust
- Snow
- Fog
- Sand

Extra Wide Lens
DC P/N 1GJ 011 872-621
AC P/N 1GJ 958 334-131



Beam Pattern Extra Wide

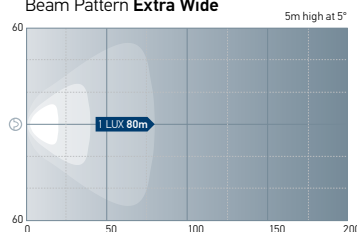

Close Range Lens
DC P/N 1GJ 011 872-601
AC P/N 1GJ 958 334-111



Beam Pattern Close Range

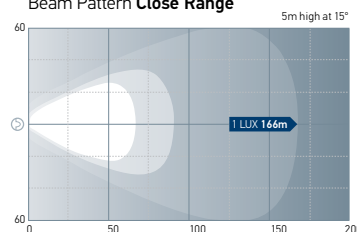

Long Range Lens
DC P/N 1GJ 011 872-611
AC P/N 1GJ 958 334-121



Beam Pattern Long Range

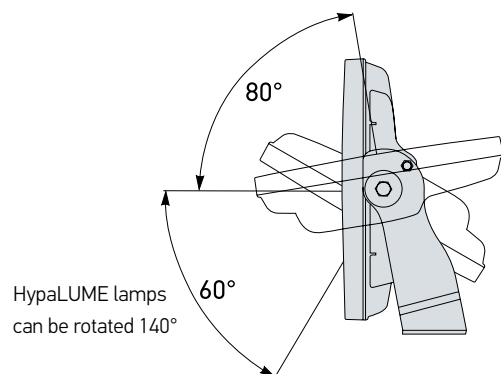
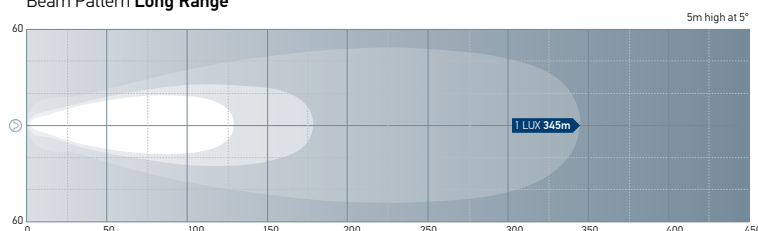

HypaLUME lamps can be rotated 140°

Amber HypaLUME 24/48V DC Flood Lights

Part Number	1GJ 011 872-621	Extra Wide
	1GJ 011 872-601	Close Range
	1GJ 011 872-611	Long Range

Power Consumption



Operating Voltage



AMBER HYPALUME 24/48V DC - SPECIFICATIONS

Operating Voltage	22 to 52V DC
Power Consumption	260W max.
Actual Light Output	19,000 lumens
Mounting	Upright or pendant
Protection	Reverse polarity, transient spike and over voltage protection IP 6K7 (Protection against dust and temporary water immersion) IP 6K9K (Protection against dust and high-pressure/steam jet cleaning) Advanced thermal management
Operating Temp.	-40°C to +50°C. Reliable in extreme environments.
LED Colour Temp.	2500 K. Optimal for visibility in Snow, Fog & Dust
Cable Length	Supplied with 1.8m of easy plug-in sheathed cable
Connection	4 Pin Deutsch plug
Lens Material	High Impact Polycarbonate
Compliance	CE FC ISO 13766 ECE R10

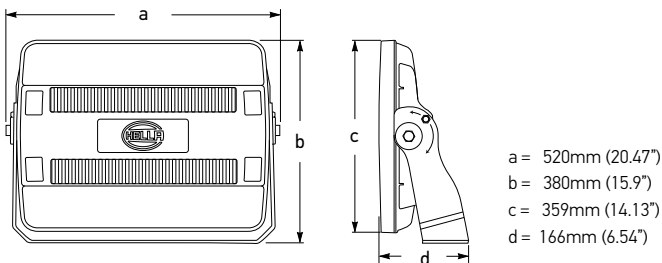

Amber HypaLUME 110/230V AC Flood Lights

Part Number	1GJ 958 334-131	Extra Wide
	1GJ 958 334-111	Close Range
	1GJ 958 334-121	Long Range

Power Consumption



Operating Voltage

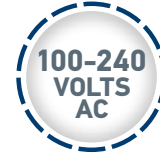

AMBER HYPALUME 110/230V AC - SPECIFICATIONS

Operating Voltage	100 to 240V AC
Power Consumption	260W max.
Actual Light Output	19,000 lumens
Mounting	Upright or pendant
Protection	IP 66 (Protection against dust and high pressure water jets) IP 67 (Protection against dust and temporary water immersion) Over voltage, short circuit and over temperature protection
Operating Temp.	-40°C to +50°C. Reliable in extreme environments.
LED Colour Temp.	2500 K. Optimal for visibility in Snow, Fog & Dust
Cable Length	Supplied with 2.0m of easy plug-in sheathed cable
Connection	Wieland RST Mini - 16A
Lens Material	High Impact Polycarbonate
Compliance	CE FC IEC 60598.2.5

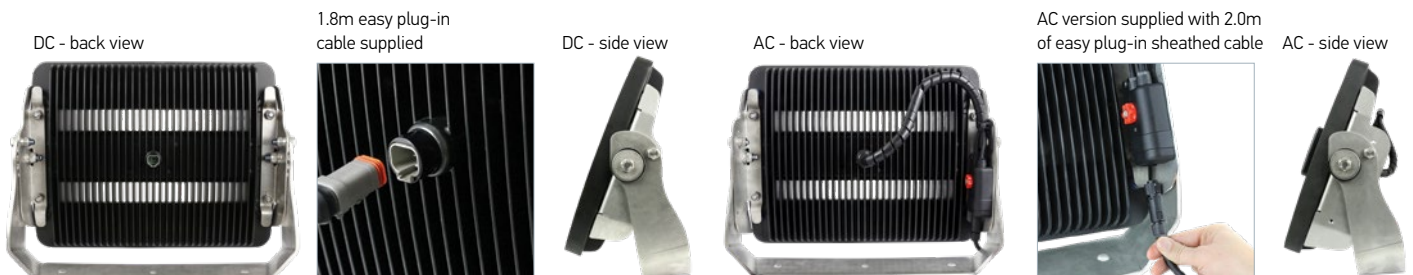
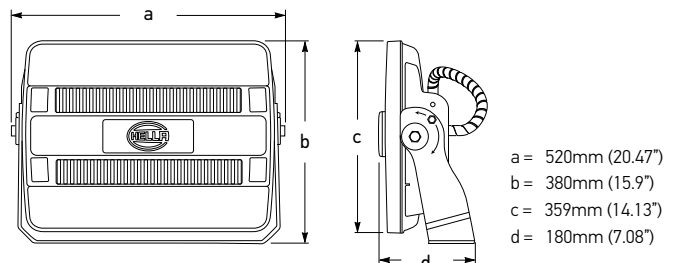

HELLA GmbH & Co. KGaA
Rixbecker Straße 75
59552 Lippstadt,
Germany
Tel: +49 2941 38-0
www.hella.com/mining

**Hella Fahrzeugteile
Austria GmbH**
Handelskai 94-96
1200 Wien, Austria
Tel: +43 (0) 1 606 89 20
www.hella.at

HELLA Australia Pty. Ltd.
4 Hargrave Place, Mentone,
Victoria 3194, Australia
Techline: 1800 061 729
Email: custservice@ha.hella.com
www.hella.com.au

HELLA-New Zealand Ltd.
81-83 Ben Lomond Crescent
Pakuranga, Auckland 2010
New Zealand
Tel: +64 (0)9 577-0366
Email: nzsales@hella.com
www.hella.co.nz

HELLA USA
HELLA Inc.
201 Kelly Drive, Peachtree City,
GA 20369, USA
Tel: (770) 631-7500
Email: soe.sales@hella.com
www.hella.com/hella-us/

www.hella.com/mining

