

# MODEL 1358LED

## 7" Round LED Headlamp Instruction Sheet



### Pre-Installation Information

In the Box:	7" Round LED Headlamp (x1)
Wire Functions:	Black = Ground
	White = High Beam
Operating Voltage:	9-32V DC



To properly install this headlamp you should have a good understanding of automotive electrical procedures and systems, and proficiency in the installation of headlamps. **IF YOU DO NOT, PLEASE SEEK PROFESSIONAL ASSISTANCE.**

### Pre-Installation Guidelines

1. Read all safety notes and mounting guidelines before installing the product. Verify that all parts listed under "In the Box" are present and complete.
2. Inspect the product for damage. DO NOT install the product if there is any damage. Contact the authorized retailer where you purchased it to initiate a warranty claim if there is damage.
3. Verify that all power supply and/or charging systems comply to the specified voltage limits for the headlamp.

All dimensions in mm.

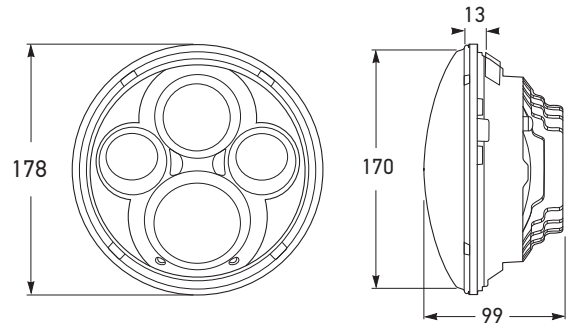

### Installation Instructions

1. Turn off the vehicle and disconnect the battery.
2. Remove the existing headlamps from the bumper. Be careful not to damage the bumper and keep all hardware that attaches the headlamp to the vehicle.
3. Unplug the connector of the existing headlamp.
4. Plug in the connector.
5. Lay and secure wires to avoid any pulling or abrasion that may damage the wires or headlamp.
6. Install the headlamp with the existing hardware into the bumper, with the HELLA logo oriented at the bottom.
7. Reconnect the battery and test that the headlamps are functioning correctly.
8. Aim the headlamps. Instructions available online from the 1358LED product page at [www.hella.co.nz](http://www.hella.co.nz).

#### Regulatory Compliance



ECE R112/01 Ref. 30 (E1) 7501

**MODEL 1358LED**  
7" Round LED Headlamp Instruction Sheet



## WARRANTY STATEMENT

**Congratulations!** The product you have selected comes from HELLA - one of the world's leading manufacturers of lighting products. The product comes with a five year warranty covering faults in materials, components or workmanship.

In the unlikely event that you should experience a confirmed warranty with a HELLA product, we will at our discretion, either repair or replace the product or refund the purchase price.

Warranty services may be obtained by returning the product within the warranty period to the Hella Dealer where the product was originally purchased. This warranty is in addition to and does not preclude any other rights or remedies available to the consumer under any local legislation related to the provision of goods or services.

Our goods come with guarantees that cannot be excluded under the Australian Consumer Law. You are entitled to a replacement or refund for a major failure and for compensation for any other reasonably foreseeable loss or damage. You are also entitled to have the goods repaired or replaced if the goods fail to be of acceptable quality and the failure does not amount to a major failure.

**This warranty does not cover:**

1. Claim/s as a result of normal wear and tear or of any modifications, alterations non-compliance of assembly, service and operating instructions and/or any unfit or improper use.
2. Any expenses incurred in the process of making the claim.

**Note:**

For lamps sold in Australia warranty services are provided by HELLA Australia Pty Ltd, 54-76 Southern Rd, Mentone VIC 3194.

Customer Service: 1800 061 729

[www.hella.com/hella-au/21.html](http://www.hella.com/hella-au/21.html)