

# INSTRUCTION SHEET

for: **Part No. 2XD 959 01x-xx**



## 83mm Round LED Signal Warning Lamp

### Lamp Mounting

1/4" Ø nut, bolt and washer have been supplied with this product. Do not mount the lamp where damage is likely to be sustained due to tie-downs and other securing devices.

Lamp should be mounted on a flat surface. Drill one mounting hole between 6.5mm and 8mm in diameter. A small 5mm location hole is also recommended to assist in mounting the lamp accurately and to stop the lamp from rotating during or after installation. This can be done using the location pin supplied \*.

If passing the cable through a hole, ensure there are no sharp edges to cut or chafe the cable.

Drill a cable exit hole 6mm diameter in the position as shown on diagram below.

Connect lamp wiring as per chart below.

Try to keep the cable as long as possible, preferably join the cable inside a sealed cable junction box.

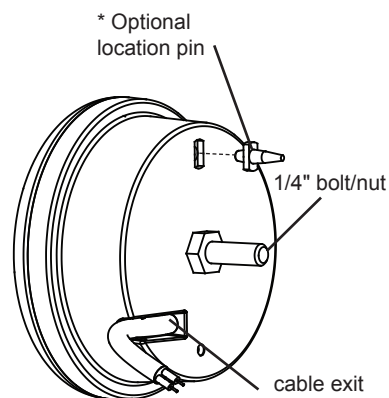

### General Dimensions (mm)

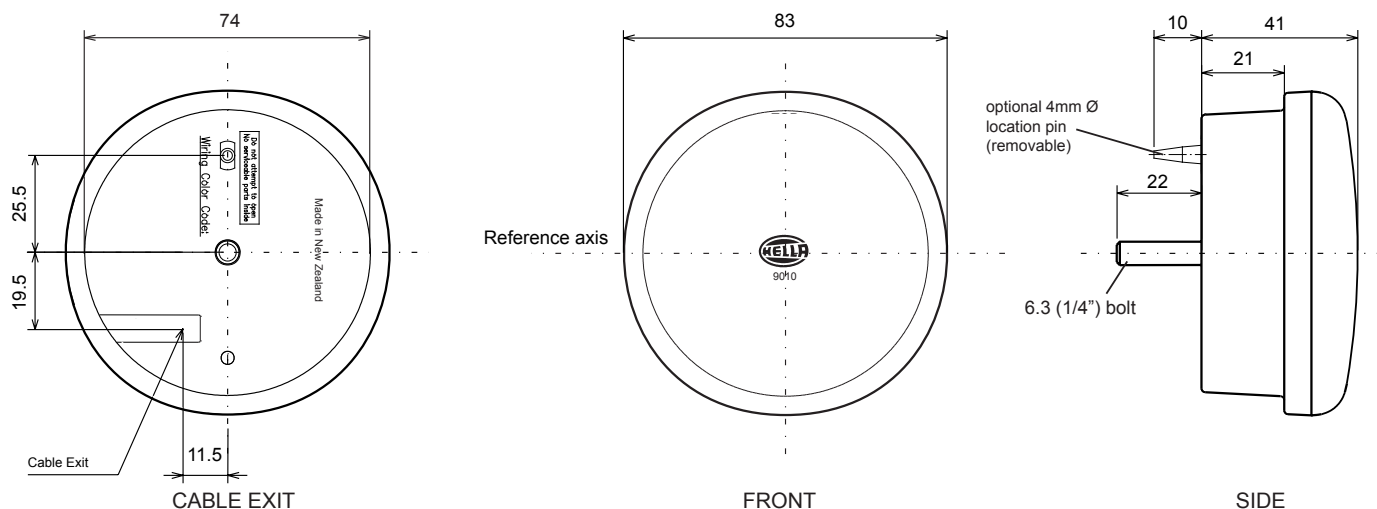

### Wiring Colour Coding

This lamp is Multivolt capable allowing full light output between 9 and 33 volts.

LED modules are polarity conscious. Reverse polarity will not damage this product but will inhibit its function.

HELLA recommends wire connections be soldered, and heat shrink tubing applied to seal the joint.

Cable Colour	Connect to	Power Consumption		
		2XD 959 010-02	2XD 959 010-7x	2XD 959 011-02
White	Negative (-)	-	-	-
Brown	Signal - Low (+)	1 watt	N/A	N/A
Red	Signal - High (+)	4 watts	N/A	N/A
Yellow	Signal (+)	N/A	6 watts	6 watts

**NB:** Lamp must be protected by a fuse rated at 5 amperes maximum.

## **Important Notes for Installer and Vehicle Owner**



### **Introduction**

Multivolt LED signal and marker lamps offer many advantages over conventional bulb lamps. Significantly reduced power consumption, ultra long life and high tolerance to shock and vibration make the LED lamps the ideal choice for the commercial transport industry, where the cost of ownership versus the initial purchase price of the product is well understood.

### **Compatibility to existing electrical systems**

It is important for the installer to ascertain the compatibility of the low power consumption LED lamps with the electrical and/or electronic systems of the complete vehicle, including trailers. In most cases the reduced power consumption is beneficial by imposing less demands on the entire electrical system.

For certain functions some electrical systems rely on a set power consumption for monitoring whether, for example, a trailer is connected.

### **Electromagnetic Compatibility (EMC)**

This Multivolt LED lamp is an electronic device. The electrical circuits contain components that suppress possible interference, both emission as well as susceptibility, to the limits prescribed in UNECE Vehicle Regulation No. 10.

To avoid false signals or interference, it is standard practice that sensitive instrumentation such as ABS and Tachometers etc. are provided with direct earths.

### **Protection against damage due to voltage spikes**

This Multivolt LED lamp is protected against damage from positive voltage spikes caused by events such as load dump conditions up to severity level 3 of ISO 7637-2 and contains a Transient Voltage Suppressor (TVS) designed to withstand a pulse of up to 5000 Watts.

The lamp is protected against reverse polarity connection and negative voltage spikes of up to 1000 volts.

### **Electric Welding**

Electric Welding may damage the LED lamps. For LED lamps, HELLA recommends the negative connection to be wired isolated from the vehicle chassis. If the lamp uses the chassis as the earth return it is recommended that this earth return is disconnected during electric welding.

## ***FIT AND FORGET - BY DESIGN***

Congratulations, the product you have selected comes from **HELLA** - a world leader in LED lighting design.



Following the launch of the first LED automotive signal lamps in 1990, **HELLA** Design and Innovation continues to set new standards. **HELLA** innovative solutions have been incorporated into millions of lamps, engineered and tested to the most stringent standards, to suit the most demanding environmental conditions.

The cornerstone to the success of our products is our no compromise **Fit and Forget - by Design** philosophy which is incorporated into every step of the product life cycle.

In a world consuming finite resources at an ever faster rate, **Fit and Forget - by Design** is the right environmental choice that also makes perfect economic sense to customers that consider the total life cycle Cost of Ownership.