



INSTRUCTION SHEET

for: **Part No. 2VB 980 720-5xx**

**APPLICATION AND MOUNTING INSTRUCTIONS**

**LED COMBINATION TRAILER LAMP  
STOP, REAR POSITION, NUMBER PLATE, REAR INDICATOR LAMP WITH REFLECTOR  
12 / 24V DC**

**Lens Marking and Installation Requirements**

This Stop / Rear Position / Number Plate / Rear Indicator Lamp with Reflector, identified by lens marking **(E24) 5860** and the **HELLA** logo was manufactured to comply with:  
ECE Regulation 3 Class IA for Retro-Reflecting Devices  
ECE Regulation 4 for Devices for the Illumination of Rear Registration Plates  
ECE Regulation 6 Category 2a for Rear Direction Indicator Lamps  
ECE Regulation 7 for Rear Position (Side) / Stop Lamps

- Lamp mounting surface must be vertical to the ground, and at right angles to the longitudinal axis of the vehicle.
  - Lamp must be visible from 45° inboard and 80° outboard, as well as from 15° above and below the horizontal axis.
  - Lamps must be mounted no less than 350 mm and no more than 900 mm above the ground.
  - Lamps to be mounted within 400 mm of the widest point of the vehicle and no closer than 600 mm together.
  - Lamp is approved to be mounted horizontally.
- Please refer to ECE Regulation 48 for more details.

Note: When mounting lamps on a trailer, additional triangular retro-reflectors (Class IIIA) are required for ECE compliance.

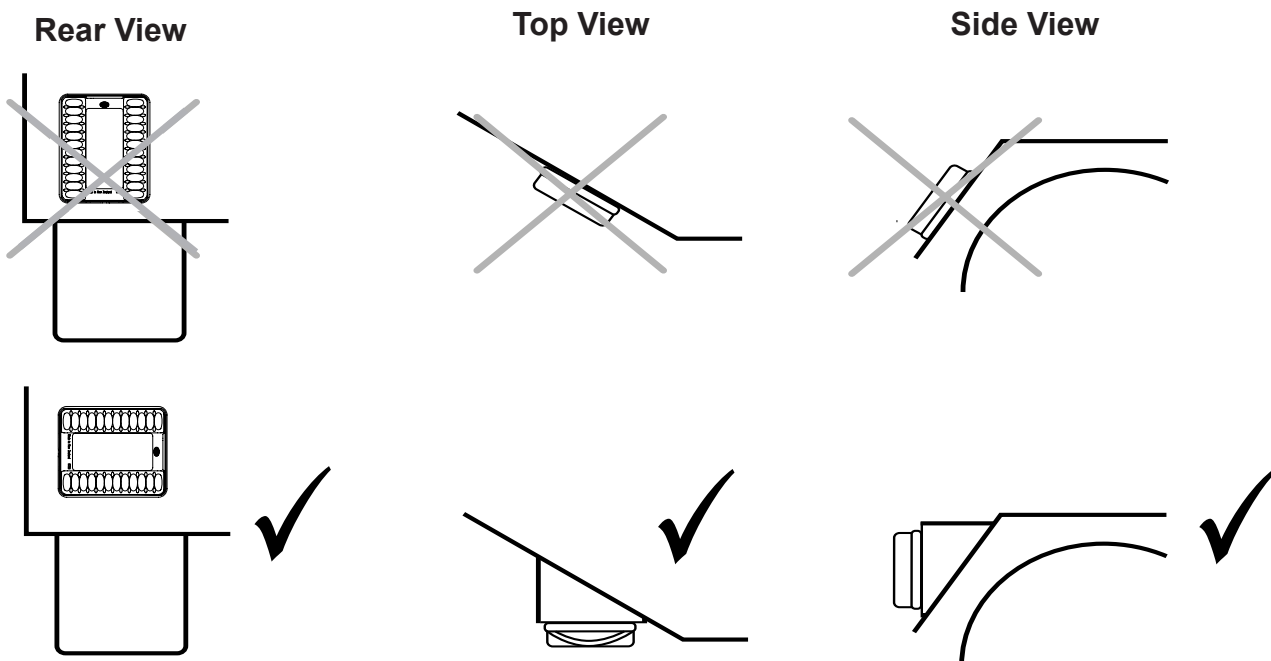

980 703-74 V06

HELLA-New Zealand Limited, Auckland



HELLA KG&A Hueck & Co.

**Mounting Instruction**  
Anbauanweisung  
Type: **2VB 980 720**  
Typ: **2VB 980 720**

LLK Ke  
31485  
13.01.2011  
Page 1 / Seite 1

Belongs to approval no.: **E24 5860**

Geht zu Gen.-Nr.:

**Rear Position, Stop Lamp, Direction-Indicator and Reflex Reflector for Automobile.**  
Schluss-, Bremsleuchte, Fahrlichtungsanzeiger und Rückstrahler für Kraftfahrzeuge.

Optionally assembled with a License Plate Lamp  
Mehrwiese zusammengebaut mit einer Kennzeichenleuchte

**Light source(s):**  
Leuchtmittel(s)

**Design voltage:** **Nominal voltage:** **Nominal power:**  
Prüfspannung: Nennspannung: Nennleistung:

Light source(s): Leuchtmittel(s)	Design voltage: Prüfspannung:	Nominal voltage: Nennspannung:	Nominal power: Nennleistung:
Rear Position Lamp Schlussleuchte	13.5V / 28.0V	12.0V - 24.0V	1.0W
Stop Lamp Bremsleuchte	13.5V / 28.0V	12.0V - 24.0V	2.0W
Direction Indicator Fahrlichtungsanzeiger	13.5V / 28.0V	12.0V - 24.0V	2.0W
License Plate Lamp Kennzeichenleuchte	13.5V / 28.0V	12.0V - 24.0V	1.0W

☆ = Centre of reference in accordance with the ECE-Regulations - No. 3, 4, 6, 7.  
☆ = Bezugspunkt nach den ECE-Regelungen - Nr. 3, 4, 6, 7.

☆ = Centre of reference for the definition for illuminating surface in accordance with the Council Directive 76/756 EEC or ECE-Regulation No. 48 (see Annex A).  
☆ = Bezugspunkt zur Bestimmung der Grenzen der leuchtenden Fläche nach 76/756 EWG bzw. ECE-Regelung Nr. 48

Markierung s. auf der Abschluss-Schleife, Maße s. Anlage A.

Axis of reference: **Parallel to the car centre line and parallel to the road.**  
Bezugsachse: **Parallel zur Fahrzeuglängsachse und parallel zur Fahrbahn.**

Mounting of the left hand unit is illustrated. Right hand unit to be mounted mirror inverted.  
Einbau des linken Gerätes dargestellt. Der Einbau des rechten Gerätes erfolgt spiegelbildlich.

The version with License Plate Lamp can be rotated 180° around the reference axis.  
Die Version mit Kennzeichenleuchte kann auch 180° Schritten gedreht um die Bezugsachse angebaut werden.

The version without License Plate Lamp can be rotated in 90° steps around the reference axis.  
Die Version ohne Kennzeichenleuchte kann auch in 90° Schritten gedreht um die Bezugsachse angebaut werden.

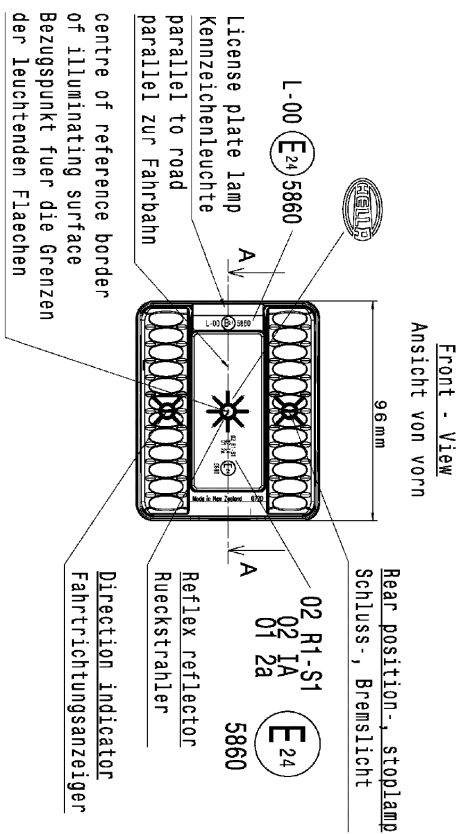

The device must be mounted according to the enclosed fitting documents (e.g. sketch + Annex A).  
Der An- bzw. Einbau der Geräte hat nach anliegenden An- bzw. Einbauunterlagen (z. B. Skizze und Anlage A) zu erfolgen.



HELLA KG&A Hueck & Co.

**Mounting Instruction**  
Anbauanweisung  
Type: **2VB 980 720**  
Typ: **2VB 980 720**

LLK Ke  
31485  
13.01.2011  
Page 2 / Seite 2

Belongs to approval no.: **E24 5860**

Geht zu Gen.-Nr.:

**Rear Position, Stop Lamp, Direction-Indicator and Reflex Reflector for Automobile.**  
Schluss-, Bremsleuchte, Fahrlichtungsanzeiger und Rückstrahler für Kraftfahrzeuge.

Optionally assembled with a License Plate Lamp  
Mehrwiese zusammengebaut mit einer Kennzeichenleuchte

**Light source(s):**  
Leuchtmittel(s)

Light source(s): Leuchtmittel(s)	Design voltage: Prüfspannung:	Nominal voltage: Nennspannung:	Nominal power: Nennleistung:
Rear Position Lamp Schlussleuchte	13.5V / 28.0V	12.0V - 24.0V	1.0W
Stop Lamp Bremsleuchte	13.5V / 28.0V	12.0V - 24.0V	2.0W
Direction Indicator Fahrlichtungsanzeiger	13.5V / 28.0V	12.0V - 24.0V	2.0W
License Plate Lamp Kennzeichenleuchte	13.5V / 28.0V	12.0V - 24.0V	1.0W

☆ = Centre of reference in accordance with the ECE-Regulations - No. 3, 4, 6, 7.  
☆ = Bezugspunkt nach den ECE-Regelungen - Nr. 3, 4, 6, 7.

☆ = Centre of reference for the definition for illuminating surface in accordance with the Council Directive 76/756 EEC or ECE-Regulation No. 48 (see Annex A).  
☆ = Bezugspunkt zur Bestimmung der Grenzen der leuchtenden Fläche nach 76/756 EWG bzw. ECE-Regelung Nr. 48

Markierung s. auf der Abschluss-Schleife, Maße s. Anlage A.

Axis of reference: **Parallel to the car centre line and parallel to the road.**  
Bezugsachse: **Parallel zur Fahrzeuglängsachse und parallel zur Fahrbahn.**

Mounting of the left hand unit is illustrated. Right hand unit to be mounted mirror inverted.  
Einbau des linken Gerätes dargestellt. Der Einbau des rechten Gerätes erfolgt spiegelbildlich.

The version with License Plate Lamp can be rotated 180° around the reference axis.  
Die Version mit Kennzeichenleuchte kann auch 180° Schritten gedreht um die Bezugsachse angebaut werden.

The version without License Plate Lamp can be rotated in 90° steps around the reference axis.  
Die Version ohne Kennzeichenleuchte kann auch in 90° Schritten gedreht um die Bezugsachse angebaut werden.

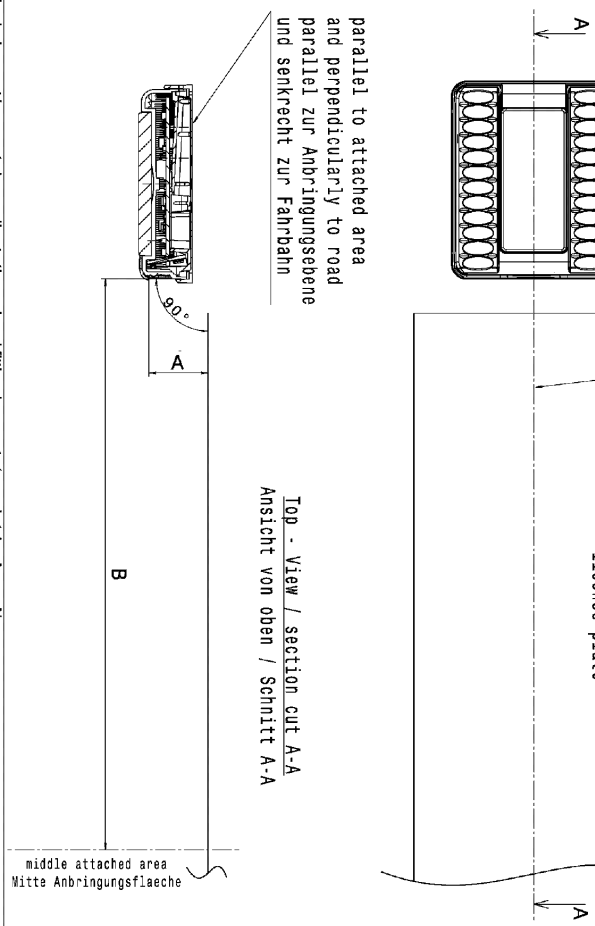

The device must be mounted according to the enclosed fitting documents (e.g. sketch + Annex A).  
Der An- bzw. Einbau der Geräte hat nach anliegenden An- bzw. Einbauunterlagen (z. B. Skizze und Anlage A) zu erfolgen.

INSTRUCTION SHEET

for: **Part No. 2VB 980 720-5xx**



**Lamp Mounting**

Drill the required number of holes through the mounting surface using the mounting frame as a template. Secure the mounting frame using low profile bolts or screws of the correct diameter. Check relevant hole diameters in the general dimension drawing below.

The mounting frame is designed so that the lamp module can be fitted with the cable exiting in one direction only. Confirm cable direction is correct before assembling the mounting frame.

Alternatively, the cable may be routed through a hole in the mounting surface. If passing the cable through a hole, ensure that there are no sharp edges to cut or chafe the cable.

Connect lamp as per wiring table below. Clip the lamp module into the mounting base ensuring that the clips have secured the lamp module. Try to keep the cable as long as possible, preferably join the cable inside a sealed cable junction box.

**Wiring Colour Coding**

This lamp allows full light output on both 12 and 24 volt vehicles and trailers. LED modules are polarity conscious. Reverse polarity will not damage this product but will inhibit its function.

HELLA recommends wire connections be soldered, and heat shrink tubing applied to seal the joint.

Colour	Connect to	Power Consumption
White	Earth (-)	-
Red	Stop (+)	2 watts
Brown	Rear Position / Number Plate (+)	1 watt
Blue	Rear Indicator (+)	2 watts

**NB:** Lamp must be protected by a fuse rated at 5 amperes maximum.

**General Dimensions (mm)**

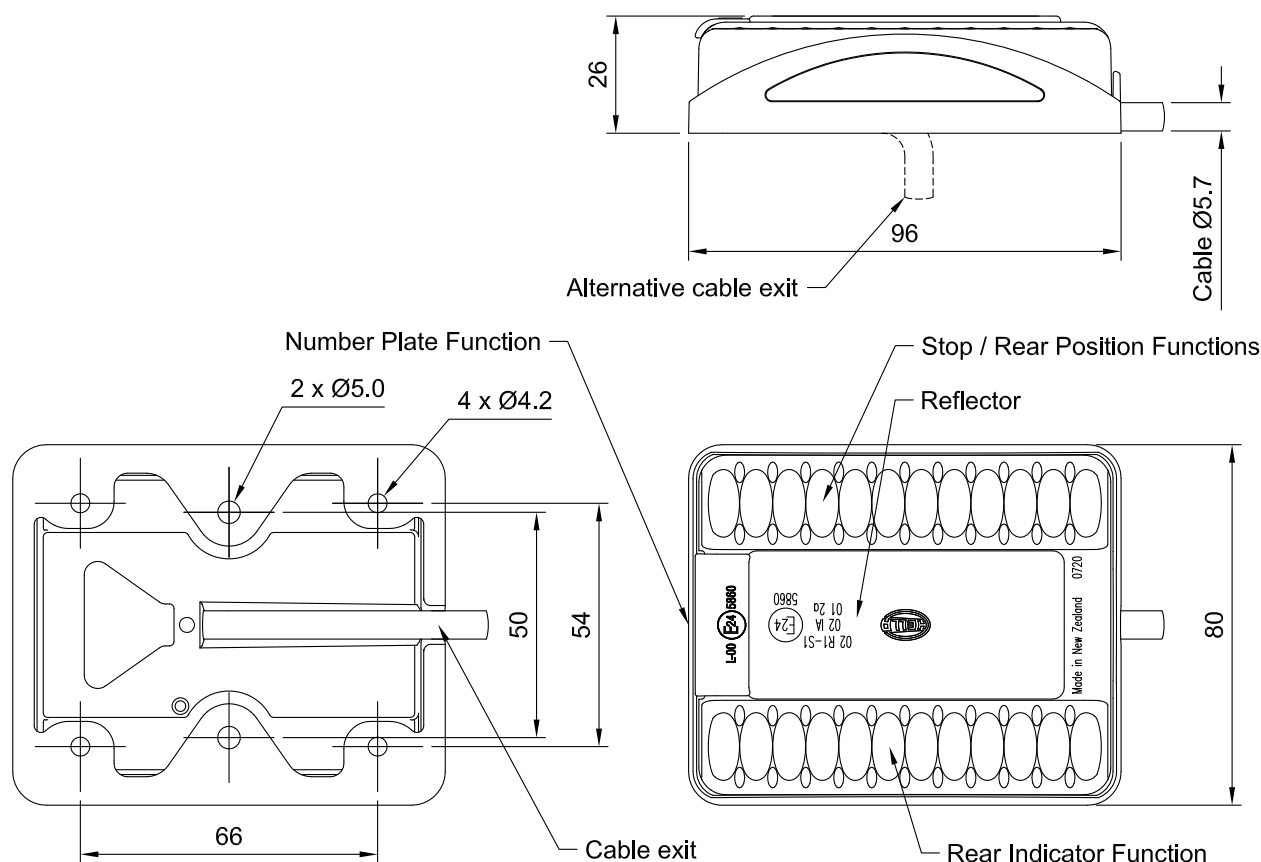

**Important Notes for Installer and Vehicle Owner**



**Introduction**

This LED lamp offers many advantages over conventional bulb lamps. Significantly reduced power consumption, ultra long life, fully sealed construction and high tolerance to shock and vibration makes this LED lamp the ideal choice for boat and small / medium sized trailers.

**Compatibility to existing electrical systems**

It is important for the installer to ascertain the compatibility of the low power consumption LED lamps with the electrical and/or electronic systems of the complete vehicle, including trailers. In most cases the reduced power consumption is beneficial by imposing less demands on the entire electrical system. For certain functions some electrical systems rely on a set power consumption for monitoring whether, for example, a trailer is connected.

**Electromagnetic Compatibility (EMC)**

This LED lamp is an electronic device. The electrical circuits contain components that suppress possible interference, both emission as well as susceptibility, to the limits prescribed in UNECE Vehicle Regulation No. 10.

**Protection against damage due to voltage spikes**

This LED lamp is protected against damage from positive voltage spikes caused by events such as load dump conditions specified in ISO 7637. The lamp is protected against reverse polarity connection and negative voltage spikes of up to 1000 volts.

**Electric Welding**

Electric Welding may damage the LED lamps. For LED lamps, HELLA recommends the negative connection to be wired isolated from the vehicle chassis. If the lamp uses the chassis as the earth return it is recommended that this earth return is disconnected during electric welding.

**FIT AND FORGET - BY DESIGN**

Congratulations, the product you have selected comes from **HELLA** - a world leader in LED lighting design.



Following the launch of the first LED automotive signal lamps in 1990, **HELLA** Design and Innovation continues to set new standards. **HELLA** innovative solutions have been incorporated into millions of lamps, engineered and tested to the most stringent standards, to suit the most demanding environmental conditions.

The cornerstone to the success of our products is our no compromise **Fit and Forget - by Design** philosophy which is incorporated into every step of the product life cycle.

In a world consuming finite resources at an ever faster rate, **Fit and Forget - by Design** is the right environmental choice that also makes perfect economic sense to customers that consider the total life cycle Cost of Ownership.

For general comments about HELLA's products please contact us on E-mail at [techfeedback@hella.co.nz](mailto:techfeedback@hella.co.nz)



# Mounting Instruction

## Anbauanweisung

LI-K Ke  
31485  
13.01.2011

HELLA KGaA Hueck & Co.

Type: **2VB 980 720**  
Typ:

Page 3 / Seite 3

Belongs to approval no.: **E24 5860**  
Gehört zu Gen.-Nr.:

**Rear Position-, Stop Lamp, Direction-Indicator and Reflex Reflector for Automobile.**

Schluss-, Bremsleuchte, Fahrtrichtungsanzeiger und Rückstrahler für Kraftfahrzeuge.

**Optionally assembled with a License Plate Lamp**

Wahlweise zusammengebaut mit einer Kennzeichenleuchte

The distance of 'A' and 'B' it must be selected in such a way that they are within the represented hatched tolerance field.

Die Abstandsmaße 'A' und 'B' müssen so gewählt werden, dass sie sich innerhalb des dargestellten schraffierten Toleranzfeldes befinden.

**Tolerance field for shield 520 x 120mm.**  
The mounting of the License Plate Lamp is on both side required.

Toleranzfeld für das Schild 520 x 120mm.

Der paarweise Anbau der Kennzeichenleuchte ist erforderlich.

Coordinates: Koordinaten:		
	A [mm]	B [mm]
f	42,4	284,5
e	51	336
d	108	392
b	160	392
c	176	367

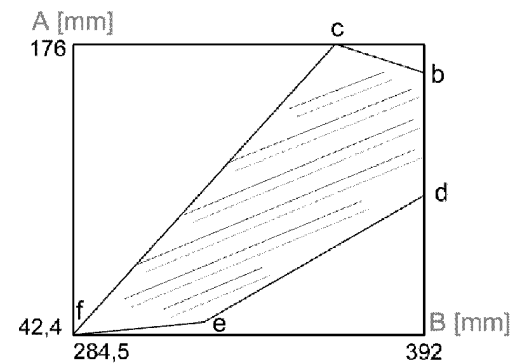

**Tolerance field for shield 340 x 240mm.**  
The mounting of the License Plate Lamp is on both side required.

Toleranzfeld für das Schild 340 x 240mm.

Der paarweise Anbau der Kennzeichenleuchte ist erforderlich.

Coordinates: Koordinaten:		
	A [mm]	B [mm]
a	32	188
b	154	259
c	139	337
d	108	345
e	82	323

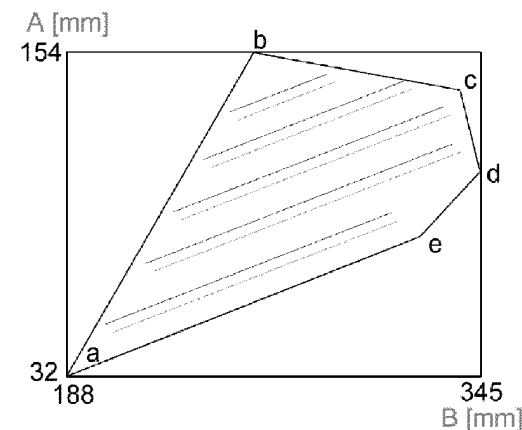

The device must be mounted according to the enclosed fitting documents (e. g. sketch + Annex A).

Der An- bzw. Einbau der Geräte hat nach anliegenden An- bzw. Einbauunterlagen (z. B. Skizze und Anlage A) zu erfolgen.



# Mounting Instruction

## Anbauanweisung

LI-K Ke  
31485  
13.01.2011

HELLA KGaA Hueck & Co.

Type: **2VB 980 720**  
Typ:

Page 4 / Seite 4

Belongs to approval no.: **E24 5860**  
Gehört zu Gen.-Nr.:

**Rear Position-, Stop Lamp, Direction-Indicator and Reflex Reflector for Automobile.**

Schluss-, Bremsleuchte, Fahrtrichtungsanzeiger und Rückstrahler für Kraftfahrzeuge.

**Optionally assembled with a License Plate Lamp**

Wahlweise zusammengebaut mit einer Kennzeichenleuchte

The distance of 'A' and 'B' it must be selected in such a way that they are within the represented hatched tolerance field.

Die Abstandsmaße 'A' und 'B' müssen so gewählt werden, dass sie sich innerhalb des dargestellten schraffierten Toleranzfeldes befinden.

**Tolerance field for shield 240 x 165mm.**  
The mounting of the License Plate Lamp is on both side required.

Toleranzfeld für das Schild 240 x 165mm.

Der paarweise Anbau der Kennzeichenleuchte ist erforderlich.

Coordinates: Koordinaten:		
	A [mm]	B [mm]
a	22	133
b	184	228
c	204	422
d	195	478
e	135	492
f	75	430

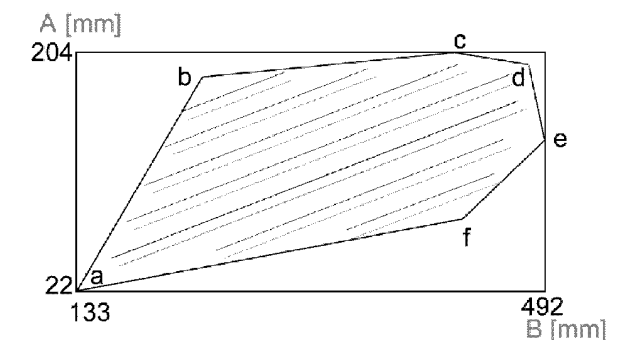

**Tolerance field for shield 240 x 165mm.**  
The mounting of the License Plate Lamp is on left or right side required.

Toleranzfeld für das Schild 240 x 165mm.

Der Anbau der Kennzeichenleuchte ist an der linken oder rechten Seite erforderlich.

Coordinates: Koordinaten:		
	A [mm]	B [mm]
a	45	152
b	110	189
c	116	210
d	95	221
e	51	184

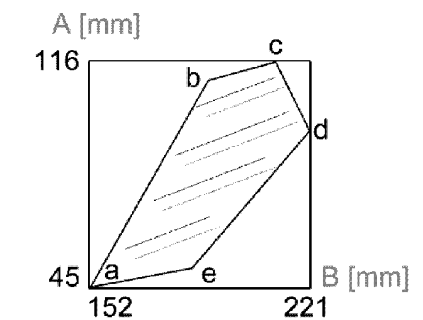

The device must be mounted according to the enclosed fitting documents (e. g. sketch + Annex A).

Der An- bzw. Einbau der Geräte hat nach anliegenden An- bzw. Einbauunterlagen (z. B. Skizze und Anlage A) zu erfolgen.